



Thermal overload relays - For use with TeSys K contactors

Type of product	Range		Pages
Adjustable thermal overload relays For motors TeSys LRK	From 0.16 to 16 A		B11/2
Adjustable thermal overload relays For unbalanced loads TeSys LRK	From 0.8 to 16 A		B11/3

Thermal overload relays Class 10 A - For use with TeSys Deca contactors

TeSys Deca adjustable thermal overload relays For motors	From 0.16 to 140 A		B11/4
TeSys Deca adjustable thermal overload relays For unbalanced loads	From 0.16 to 140 A		B11/4

Thermal overload relays Class 20 - For use with TeSys Deca contactors

TeSys Deca adjustable thermal overload relays For motors	From 0.63 to 80 A		B11/6
TeSys Deca adjustable thermal overload relays For unbalanced loads	From 0.63 to 32 A		B11/6

Electronic thermal overload relays - For use with TeSys Deca contactors

TeSys Deca adjustable electronic overload relay, Multi-class, multi-scale	From 0.1 to 150 A		B11/10
--	-------------------	---	--------

Electronic overload relays - For use with TeSys Giga contactors

TeSys LR9G electronic overload relays To protect against overload, phase imbalance, phase loss and ground fault	From 28 to 630 A		B11/11
---	------------------	---	--------



Single pole magnetic over current relays

TeSys RM1 Latching or non latching overload relays	From 1.15 to 630 A		B11/15
---	--------------------	---	--------

Thermistor-type protection units – For use detection of motor overheating

TeSys LT3 Protection units and PTC probes, with or without fault memory	From 90 to 170 °C		B11/17
--	-------------------	---	--------

Electronic over current relays - For machine protection

Predefined or adjustable starting times, Manual reset	From 1.5 to 34 A		B11/19
Automatic, electric or manual reset	From 0.5 to 50 A		B11/19

Overload
relays

3-pole thermal overload relays for TeSys K contactors

These overload relays are designed for the protection of motors. They are compensated and phase failure sensitive. Resetting can either be manual or automatic.

Direct mounting: under the contactor for versions with screw clamp terminals only; pre-wired terminals, see pages B11/28 and B11/30.

Separate mounting: using terminal block LA7K0064 (see below).

On the front face of the overload relay:

- selection of reset mode: Manual (marked H) or Automatic (marked A),
- red pushbutton: Trip Test function,
- blue pushbutton: Stop and manual Reset,
- yellow trip flag indicator: overload relay tripped.

Protection by magnetic circuit breaker GV2LE, see pages coordination tables chapter A6.

Class 10 A (the standard specifies a tripping time of between 2 and 10 seconds at 7.2 In)

Relay setting range	Fuses to be used with selected relay Maximum rating Type			Reference
	aM	gG	BS88	
	A	A	A	
0.11...0.16	0.25	0.5	–	LR2K0301
0.16...0.23	0.25	0.5	–	LR2K0302
0.23...0.36	0.5	1	–	LR2K0303
0.36...0.54	1	1.6	–	LR2K0304
0.54...0.8	1	2	–	LR2K0305
0.8...1.2	2	4	6	LR2K0306
1.2...1.8	2	6	6	LR2K0307
1.8...2.6	4	8	10	LR2K0308
2.6...3.7	4	10	16	LR2K0310
3.7...5.5	6	16	16	LR2K0312
5.5...8	8	20	20	LR2K0314
8...11.5	10	25	20	LR2K0316
10...14	16	32	25	LR2K0321
12...16	20	40	32	LR2K0322

Overload relays for unbalanced loads

Class 10 A: to order, replace the prefix LR2 by LR7 in the references selected from above (only applicable to overload relays LR2K0305 to LR2K0322).

Example: LR7K0308.



PE12393JUF

LR2K0307

TeSys Protect

TeSys Protect accessory for LRK Thermal overload relays

Product references



FB121488.eps

LA7K0064

Accessory for TeSys LRK Thermal overload relay

Description	Type of connection	Reference
Terminal block for separate clip-on mounting of the overload relay on 35 mm rail	Screw clamp	LA7K0064

TeSys Protect

Deca Thermal overload relays

Product references

3-pole differential thermal overload relays for Deca contactors - Class 10A

- for use with fuses or magnetic circuit breakers ref. GV2L and GV3L
- compensated relays with manual or automatic reset
- with relay trip indicator
- for a.c. or d.c.

Relay setting range (A)	Fuses to be used with selected relay			For use with contactor LC1	Reference	Weight kg
	aM (A)	gG (A)	BS88 (A)			
Class 10 A ⁽¹⁾ for connection by screw clamp terminals or connectors						
0.10...0.16	0.25	2	–	D09...D38	LRD01	0.124
0.16...0.25	0.5	2	–	D09...D38	LRD02	0.124
0.25...0.40	1	2	–	D09...D38	LRD03	0.124
0.40...0.63	1	2	–	D09...D38	LRD04	0.124
0.63...1	2	4	–	D09...D38	LRD05	0.124
1...1.6	2	4	6	D09...D38	LRD06	0.124
1.6...2.5	4	6	10	D09...D38	LRD07	0.124
2.5...4	6	10	16	D09...D38	LRD08	0.124
4...6	8	16	16	D09...D38	LRD10	0.124
5.5...8	12	20	20	D09...D38	LRD12	0.124
7...10	12	20	20	D09...D38	LRD14	0.124
9...13	16	25	25	D12...D38	LRD16	0.124
12...18	20	35	32	D18...D38	LRD21	0.124
16...24	25	50	50	D25...D38	LRD22	0.124
23...32	40	63	63	D25...D38	LRD32	0.124
30...38	40	80	80	D32 and D38	LRD35	0.124
Class 10 A ⁽¹⁾ for connection by EverLink[®] BTR screw connectors ⁽²⁾						
9...13	16	25	25	D40A...D65A	LRD313	0.375
12...18	20	32	35	D40A...D65A	LRD318	0.375
17...25	25	50	50	D40A...D65A	LRD325	0.375
23...32	40	63	63	D40A...D65A	LRD332	0.375
30...40	40	80	80	D40A...D65A	LRD340	0.375
37...50	63	100	100	D40A...D65A	LRD350	0.375
48...65	63	100	100	D50A and D65A	LRD365	0.375
62...80	80	125	125	D80A	LRD380	0.375
Class 10 A ⁽¹⁾ for connection by screw clamp terminals or connectors						
17...25	25	50	50	D80 and D95	LRD3322	0.510
23...32	40	63	63	D80 and D95	LRD3353	0.510
30...40	40	100	80	D80 and D95	LRD3355	0.510
37...50	63	100	100	D80 and D95	LRD3357	0.510
48...65	63	100	100	D80 and D95	LRD3359	0.510
55...70	80	125	125	D80 and D95	LRD3361	0.510
63...80	80	125	125	D80 and D95	LRD3363	0.510
80...104	100	160	160	D80 and D95	LRD3365	0.510
80...104	125	200	160	D115 and D150	LRD4365	0.900
95...120	125	200	200	D115 and D150	LRD4367	0.900
110...140	160	250	200	D150	LRD4369	0.900
80...104	100	160	160	⁽³⁾	LRD33656	1.000
95...120	125	200	200	⁽³⁾	LRD33676	1.000
110...140	160	250	200	⁽³⁾	LRD33696	1.000

Class 10 A ⁽¹⁾ for connection by lugs

Select the appropriate overload relay with screw clamp terminals or connectors from the table above and add one of the following suffixes:

- figure 6 for relays LRD01 to LRD35 and relays LRD313 to LRD380.
- **A66** for relays LRD3322 to LRD3363.

Relays LRD43●● are suitable, as standard, for use with lug-clamps.

Thermal overload relays for use with unbalanced loads

Class 10 A ⁽¹⁾ for connection by screw clamp terminals or lugs

In the references selected above, change the prefix **LRD** (except **LRD43●●**) to **LR3D**.

Example: **LRD02** becomes **LR3D02**.

Example with EverLink[®] connectors: **LRD340** becomes **LR3D340**.

Example with lugs: **LRD3806** becomes **LR3D3806**.

⁽¹⁾ Standard IEC 60947-4-1 specifies a tripping time for 7.2 times the setting current I_n ; class 10 A: between 2 and 10 seconds.

⁽²⁾ BTR screws: hexagon socket head. In accordance with local electrical wiring regulations, a size 4 insulated Allen key must be used (reference **LADALLEN4**, see page B8/42).

⁽³⁾ Independent mounting of the contactor.

Please check the availability of your variant in the index page B11/20. The SEARCH function of your viewer can be used.



LRD01



LRD330



LRD430



LRD306

Overload relays

Characteristics:
pages B11/31 to B11/34

Dimensions:
pages B11/35 to B11/37

Schemes:
page B11/37

TeSys Protect

Deca Thermal overload relays

Product references



LRD3303

3-pole differential thermal overload relays for Deca contactors - Class 10 A

- for use with fuses or magnetic circuit breakers ref. GV2L and GV3L
- compensated relays with manual or automatic reset
- with relay trip indicator
- for a.c. or d.c.

Relay setting range (A)	Fuses to be used with selected relay			For use with contactor LC1	Reference
	aM (A)	gG (A)	BS88 (A)		
Classes 10 A ⁽¹⁾ for connection by spring terminals (only for direct mounting beneath the contactor)					
1...1.6	2	4	6	D09...D38	LRD063
1.6...2.5	4	6	10	D09...D38	LRD073
2.5...4	6	10	16	D09...D38	LRD083
4...6	8	16	16	D09...D38	LRD103
5.5...8	12	20	20	D09...D38	LRD123
7...10	12	20	20	D09...D38	LRD143
9...13	16	25	25	D12...D38	LRD163
12...18	20	35	32	D18...D38	LRD213
16...24	25	50	50	D25...D38	LRD223

Class 10 A with connection by EverLink® BTR screw connectors ⁽²⁾ and control by spring terminals

23...32	40	63	63	D40A...D65A	LRD3323
37...50	63	100	100	D40A...D65A	LRD3503
48...65	63	100	100	D50A and D65A	LRD3653
62...80	80	125	125	D80A	LRD3803

Thermal overload relays for use with unbalanced loads

Classes 10 A ⁽¹⁾ for connection by BTR screw connectors ⁽²⁾ and control by spring terminals

In the references selected above, replace LRD3 with LR3D3.
Example: LRD3803 becomes LR3D3803.

Thermal overload relays for use on 1000 V supplies

Classes 10 A ⁽¹⁾ for connection by screw clamp terminals

For relays LRD06 to LRD35 only, for an operating voltage of 1000 V, and only for independent mounting, the reference becomes **LRD33...A66**.
Order an **LA7D3064** terminal block separately, see page B11/9.

Standard relay	Relay for 1000 V network
LRD32	LRD3353A66

⁽¹⁾ Standard IEC 60947-4-1 specifies a tripping time for 7.2 times the setting current I_R ; class 10 A: between 2 and 10 seconds.

⁽²⁾ BTR screws: hexagon socket head. In accordance with local electrical wiring regulations, a size 4 insulated Allen key must be used (reference **LADALLEN4**, see page B8/42).

Please check the availability of your variant in the index page B11/20. The SEARCH function of your viewer can be used.



TeSys Protect

Deca Thermal overload relays

Product references

3-pole differential thermal overload relays for Deca contactors - Class 20

- for use with fuses or magnetic circuit breakers ref. GV2L and GV3L
- compensated relays with manual or automatic reset
- with relay trip indicator
- for a.c. or d.c.



LRD05L...LRD32L

Relay setting range (A)	Fuses to be used with selected relay			For use with contactor LC1	Reference
	aM (A)	gG (A)	BS88 (A)		
Classes 20 ⁽¹⁾ for connection by screw clamp terminals					
0.63...1	2	4	-	D09...D38	LRD05L
1...1.6	2	4	6	D09...D38	LRD06L
1.6...2.5	4	6	10	D09...D38	LRD07L
2.5...4	6	10	16	D09...D38	LRD08L
4...6	8	16	16	D09...D38	LRD10L
5.5...8	12	20	20	D09...D38	LRD12L
7...10	12	20	20	D09...D38	LRD14L
9...13	16	25	25	D12...D38	LRD16L
12...18	20	35	32	D18...D38	LRD21L
17...24	25	50	50	D25...D38	LRD22L
23...32	40	63	63	D25...D38	LRD32L

Class 20 ⁽¹⁾ for connection by EverLink® BTR screw connectors ⁽²⁾

9...13	20	32	35	D40A...D65A	LRD313L
12...18	25	40	40	D40A...D65A	LRD318L
17...25	32	50	50	D40A...D65A	LRD325L
23...32	40	63	63	D40A...D65A	LRD332L
30...40	50	80	80	D40A...D65A	LRD340L
37...50	63	100	100	D40A...D65A	LRD350L
48...65	80	125	125	D50A and D65A	LRD365L

Classes 20 ⁽¹⁾ for connection by screw clamp terminals

17...25	32	50	50	D80 and D95	LR2D3522
23...32	40	63	63	D80 and D95	LR2D3553
30...40	40	100	80	D80 and D95	LR2D3555
37...50	63	100	100	D80 and D95	LR2D3557
48...65	80	125	100	D80 and D95	LR2D3559
55...70	100	125	125	D80 and D95	LR2D3561
63...80	100	160	125	D80 and D95	LR2D3563

Class 20 ⁽¹⁾ for connection by lugs

For relays LRD05L to LRD32L and relays LRD313L to LRD365L, select the appropriate overload relay with screw clamp terminals or connectors from the table above and add the suffix **6**.

Example: **LRD05L** becomes **LRD05L6**.

Thermal overload relays for use with unbalanced loads

Class 20 ⁽¹⁾ for connection by screw clamp terminals or lugs

For relays LRD05L to LRD32L and relays LR2D3522 to LR2D3563, select the appropriate overload relay with screw clamp terminals or connectors from the table above and change the prefix LRD or LR2D to **LR3D**.

Example: **LRD05L** becomes **LR3D05L**.

(1) Standard IEC 60947-4-1 specifies a tripping time for 7.2 times the setting current I_R :
class 20: between 6 and 20 seconds

(2) BTR screws: hexagon socket head. In accordance with local electrical wiring regulations, a size 4 insulated Allen key must be used (reference **LADALLEN4**, see page B8/42).

Please check the availability of your variant in the index page B11/20. The **SEARCH** function of your viewer can be used.



LR2D35●●

Overload relays

3-pole differential thermal overload relays for Deca contactors - Class 20

- for use with fuses or magnetic circuit breakers ref. GV2L and GV3L
- compensated relays with manual or automatic reset
- with relay trip indicator
- for a.c. or d.c.

Relay setting range (A)	Fuses to be used with selected relay			For mounting beneath contactor LC1	Reference
	aM (A)	gG (A)	BS88 (A)		
Class 20 ⁽¹⁾ with connection by EverLink® BTR screw connectors ⁽²⁾ and control by spring terminals					
9...13	20	32	35	D40A...D65A	LRD313L3

(1) Standard IEC 60947-4-1 specifies a tripping time for 7.2 times the setting current I_R :
class 10: between 4 and 10 seconds,
class 10 A: between 2 and 10 seconds,
class 20: between 6 and 20 seconds.

(2) BTR screws: hexagon socket head. In accordance with local electrical wiring regulations, a size 4 insulated Allen key must be used (reference **LADALLEN4**, see page B8/42).



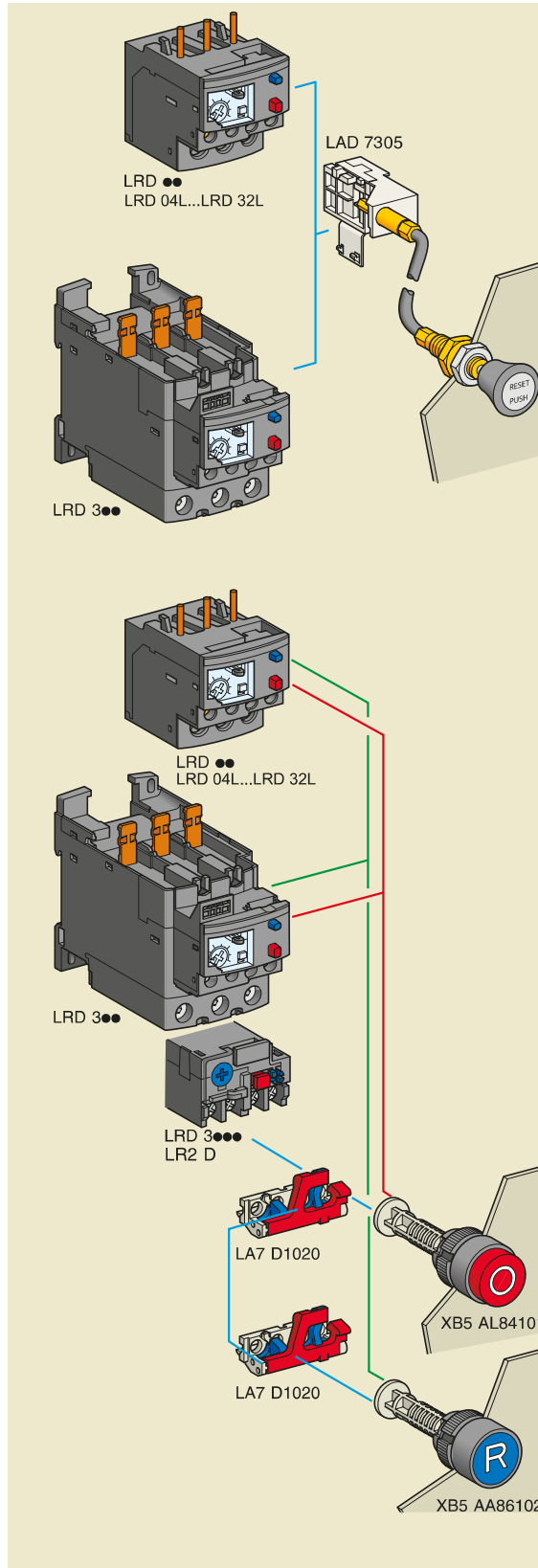
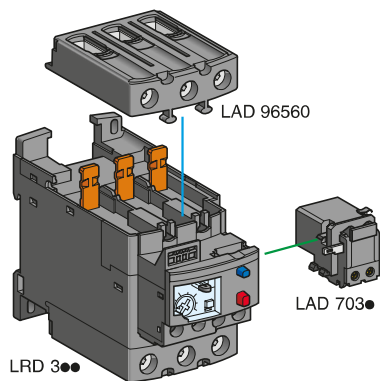
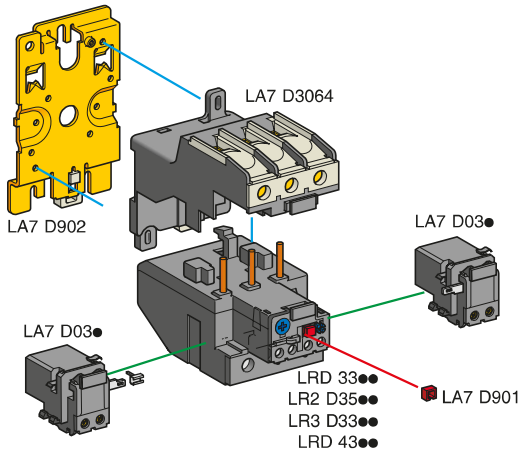
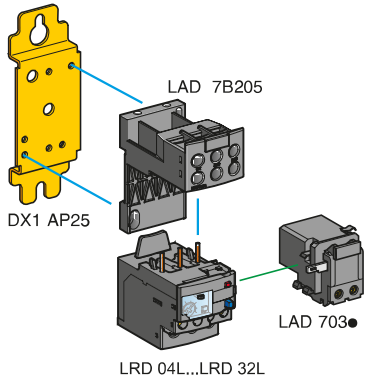
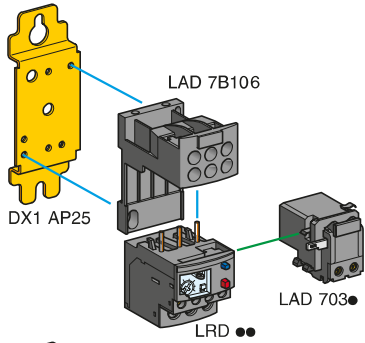

Overload relays

TeSys Protect

TeSys Deca accessories for Deca Thermal overload relays

Product references

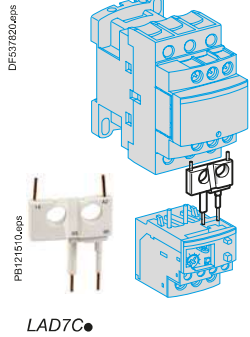

LAD7C

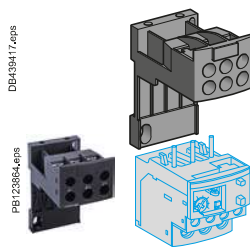

LAD7B106

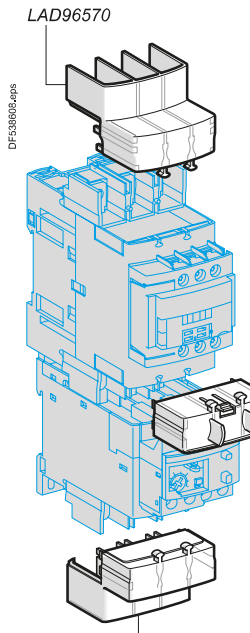

LAD96570

LAD96575

Separate components for relays

Description	For use with	Sold in lots of	Unit reference
Pre-wiring kit allowing direct connection of the N/C contact of relay LRD01...35 or LR3D02...D35 to the contactor	LC1D09...D18 LC1D25...D38	10 10	LAD7C1 ⁽¹⁾ LAD7C2 ⁽¹⁾
Terminal block ⁽²⁾ for clip-on mounting on 35 mm rail (AM1DP200) or screw fixing; for fixing centres, see pages B11/35 to B11/37	LRD01...35 and LR3D02...D35 LRD05L...LRD32L, LR3D05L...LR3D32L LRD33●●, LR3D33●●, LR2D35●●, LR3D35●●	1 1 1	LAD7B106 LAD7B205 LA7D3064 ⁽³⁾
EverLink® terminal block for independent mounting	LRD3●●, LR3D3●●L and LR3D3●●	1	LAD96560
Size 4 Allen key, insulated, 1000 V	LRD3●●, LR3D3●●L and LR3D3●●	5	LADALLEN4
Terminal block adapter for mounting a relay beneath an LC1D115 or D150 contactor	LRD33●●, LR3D33●●, LR3D35●●	1	LA7D3058 ⁽³⁾
Mounting plates ⁽⁴⁾ for screw fixing on 110 mm centres	LRD01...35, LR3D02...D35, LRD05L...LRD32L, LR3D05L...LR3D32L LRD3●●●, LR3D3●●●, LR2D35●●	10 1	DX1AP25 LA7D902
Marker holders, snap-in 8 x 18 mm	LRD3●●	100	LAD90
	All relays except LRD01...35, LRD05L...32L, LR3D05L...D32L, LR3D02...D35, LRD3●●, LR3D3●●L and LR3D3●●	100	LA7D903
Bag of 400 blank legends (self-adhesive, 7 x 16 mm)	All relays	1	LA9D91
Remote Stop or electrical reset device ⁽⁵⁾	LRD01...35, LR3D02...D35, LRD05L...32L, LR3D05L...D32L and LRD313...LRD380	1	LAD703● ⁽⁶⁾⁽⁷⁾
Remote tripping or electrical reset device ⁽⁵⁾	All relays except LRD01...35, LR9D01...32, LRD05L...32L, LR3D05L...D32L, LR3D02...D35, LR9D01...32, LRD3●●, LR3D3●●L and LR3D3●●	1	LA7D03● ⁽⁶⁾
Block of insulated terminals	LR9D	2	LA9F103 ⁽⁷⁾
IP 20 cover for lug type terminals for independent mounting	LRD3256...3806	1	LAD96570
IP 20 cover for lug type terminals for mounting with contactor LC1D40A6...D65A6	LRD3256...3806	1	LAD96575
Terminal block for lug type terminals for independent mounting	LRD3256...3806	1	LAD96566

Remote control

"Reset" function

Description	For use with	Sold in lots of	Unit reference
By flexible cable (length = 0.5 m)	LRD01...35, LR3D02...D35, LR3D05L...D32L and LR3D313...LRD380, LRD05L...LRD32L	1	LAD7305 ⁽⁸⁾
	All relays except LRD01...35, LR3D02...D35, LRD3●●, LRD05L...32L, LR3D05L...D32L, LRD3●●L, LR3D3●●, LR9D01	1	LA7D305

"Stop" and/or "Reset" functions

The terminal protection shroud must be removed and the following 3 products must be ordered separately:

Adapter for door mounting	LRD33●●, LR2D	1	LA7D1020
Operating heads for spring return pushbutton	Stop	All relays	1 XB5AL84101
	Reset	All relays	1 XB5AA86102

- (1) These pre-wiring kits cannot be used with reversing contactors.
- (2) Terminal blocks are supplied with terminals protected against direct finger contact and screws in the open, "ready-to-tighten" position.
- (3) To order a terminal block for connection by lugs, the reference becomes LA7D30646.
- (4) Remember to order the terminal block corresponding to the type of relay.
- (5) The time for which the coil of remote tripping or electrical resetting device LA7D03 or LAD703 can remain energised depends on its rest time: 1 s pulse duration with 9 s rest time; 5 s pulse duration with 30 s rest time; 10 s pulse duration with 90 s rest time; maximum pulse duration 20 s with a rest time of 300 s. Minimum pulse time: 200 ms.
- (6) Reference to be completed by adding the code indicating the control circuit voltage.
Standard control circuit voltages (for other voltages, please consult your Regional Sales Office):

Volts	12	24	48	96	110	220/230	380/400	415/440
50/60 Hz	—	B	E	—	F	M	Q	N
Consumption, inrush and sealed: < 100 W	—	J	B	E	DD	F	M	—
Consumption, inrush and sealed: < 100 W.	—	J	B	E	DD	F	M	—

- (7) Only one terminal block can be mounted below LR9D.
- (8) Not compatible with 3-pole relays fitted with spring terminals.

Overload relays

TeSys Protect

Deca Electronic thermal overload relays

Product references



LR9D0 and LR9D32



LR9D5567



LAD7B205



LAD7B205 mounted on LR9D01



LR9D67

Electronic thermal overload relays for Deca contactors

- for use with fuses or magnetic circuit breakers
- compensated relays, with relay trip indicator,
- for a.c.,
- for direct mounting on contactor or independent mounting ⁽¹⁾.

Relay setting range	Fuses to be used with selected relay		For direct mounting beneath contactor LC1	Reference
	aM	gG		
A	A	A		
Classes 5, 10, 20, 30 ⁽¹⁾ selectable for direct connection on Deca contactors or connection using connectors				
0.1...0.5			D09...D38	LR9D01
0.4...2			D09...D38	LR9D02
1.6...8			D09...D38	LR9D08
6.4...32			D09...D38	LR9D32
Classes 10 or 10 A ⁽¹⁾ for connection using bars or connectors				
60...100	100	160	D115...D150	LR9D5367
90...150	160	250	D115...D150	LR9D5369
Classes 20 ⁽¹⁾ for connection using bars or connectors				
60...100	125	160	D115...D150	LR9D5567
90...150	200	250	D115...D150	LR9D5569

Separate components for relays

Description	For use with	Sold in lots of	Unit reference
Terminal block ⁽²⁾ For clips-on mounting on 35 mm rails (AM1DP200) or screws fixing; for fixing centres, see pages B11/35 to B11/37	LR9D01, LR9D02, LR9D08, LR9D32	1	LAD7B205

Electronic overload relays for balanced or unbalanced loads

Relay setting range	Fuses to be used with selected relay		For direct mounting beneath contactor LC1	Reference
	aM	gG		
A	A	A		
Classes 10 or 20 ⁽¹⁾ selectable for direct connection using bars or connectors				
60...100	100	160	D115...D150	LR9D67
90...150	160	250	D115...D150	LR9D69

- ⁽¹⁾ Standard IEC 60947-4-1 specifies a tripping time for 7.2 times the setting current $I_{r'}$:
- class 5: between 0.5 and 5 seconds
 - class 10: between 4 and 10 seconds
 - class 10 A: between 2 and 10 seconds
 - class 20: between 6 and 20 seconds
 - class 30: between 9 and 30 seconds.

- ⁽²⁾ Terminal blocks are supplied with terminals protected against direct finger contact and screws in the open, "ready-to-tighten" position.

TeSys Protect

Giga Electronic overload relays

Introduction

> Intelligent design for greater advantages

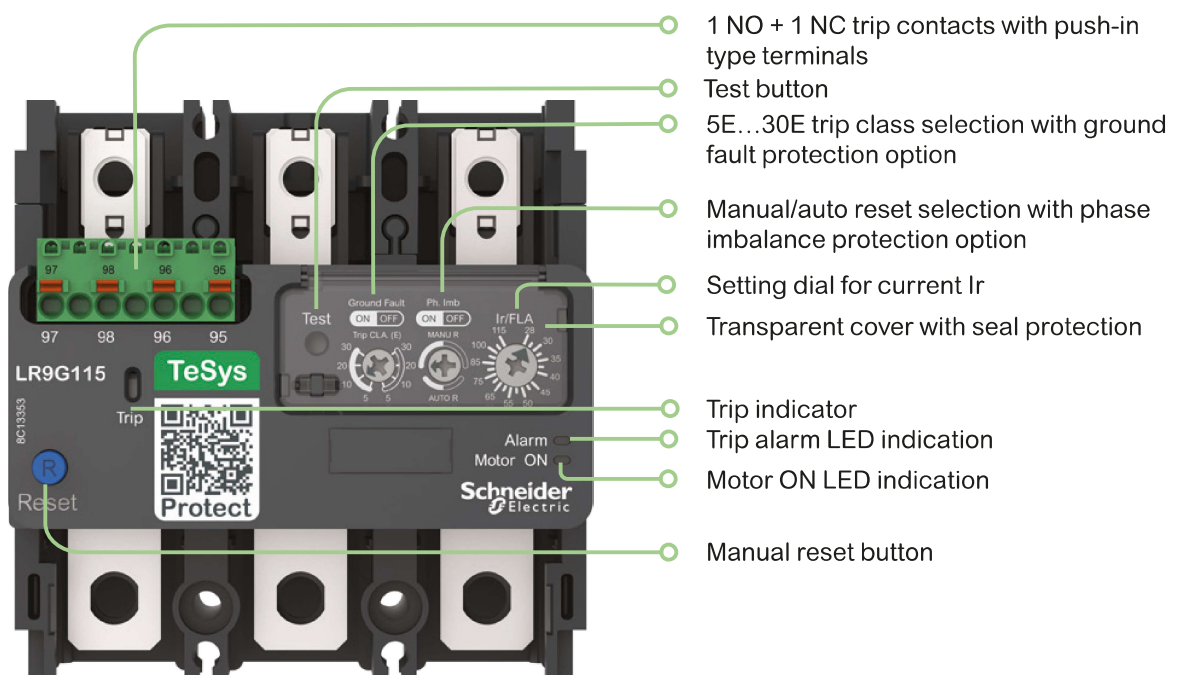
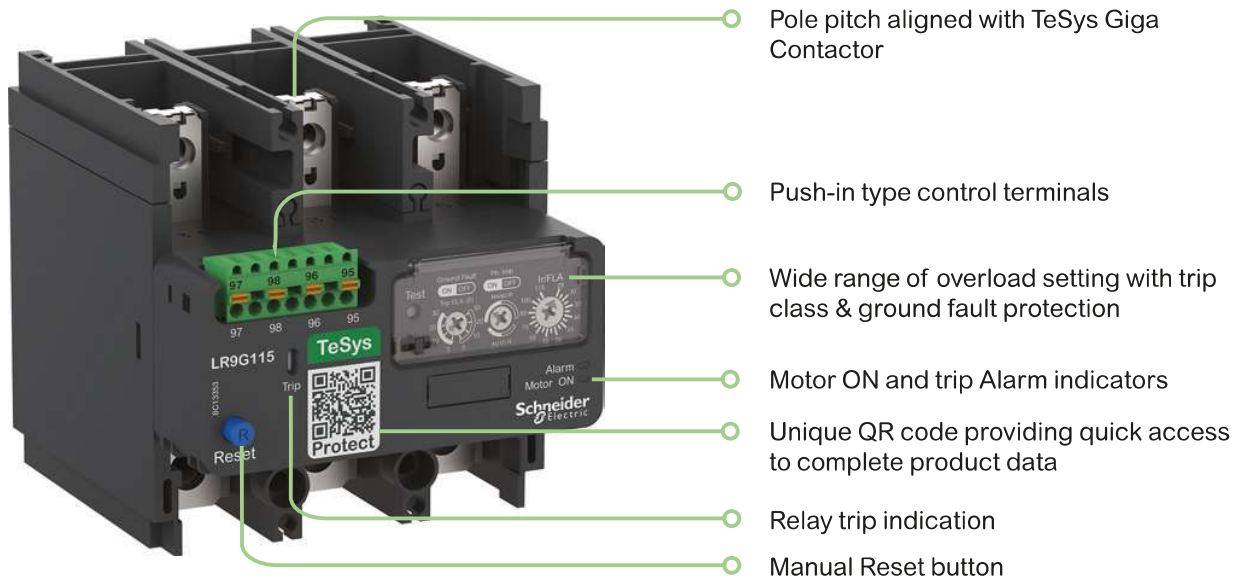

Overload
relays

TeSys Protect

Giga Electronic overload relays

Description

> Perfect selection for your motor protection

Range

- A comprehensive range of TeSys Giga Electronic overload relays in 3 sizes
- Direct mounting of relay with contactors saving in panel space and installation time



28...115 A and 57...225 A



125...500 A



160...630 A

Overload relays

- Advanced electronic monitoring with high accuracy
- Thermal compensation for ambient temperatures up to 60 °C
- Wide range of current settings, 0.25...1 I_r setting
- Direct and separately mountable to manage panel design
- Pole pitch alignment with contactors, enabling direct mounting
- Push-in terminals for quick and easy control wiring options
- 4 references covering the complete range means less inventory
- Manual and auto reset to suit your needs
- Multiple reset options: Manual, Automatic & Remote
- Protection against phase loss
- Selectable protection against imbalanced load
- Selectable protection against ground fault
- ON status and overload alarm signaling by LED
- TRIP indicator

Certifications

- Multiple standards
- International certifications

Trip class

- Selectable, from class 5E to class 30E to suit different application needs

> Product references – coding principle

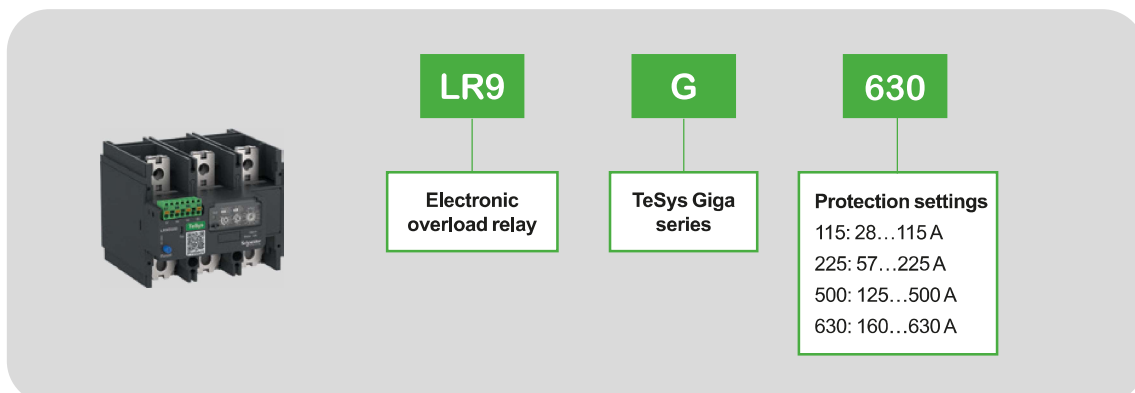

TeSys Protect

Giga Electronic overload relays

Product references



LR9G225



Direct mounting
with TeSys Giga Contactor



LA9G3650



LA9G82



LA9G3704

TeSys Giga Electronic overload relays

- Electronic overload relay
- Suitable for independent mounting or direct mounting with TeSys Giga contactors
- Ergonomic rotary switches for thermal and protection settings
- Trip class selection: 5E/10E/20E/30E
- Overload, phase imbalance, phase loss and ground fault protections
- Manual and auto reset options
- LED indicator for Motor ON and pre-trip alarm
- Thermal memory and compensation
- Push-in terminals for control connections

Relay setting range	Fuses to be used with selected relay		For direct mounting beneath contactor LC1G	Reference
	aM /gG/aR	kA		
A	A			
Class 5E...30E				
28...115	125 aM	100	LC1G115...225	LR9G115
57...225	250 aM	100	LC1G115...225	LR9G225
125...500	630 aM	100	LC1G265...500	LR9G500
	630 gG	80		
	630 aR	25		
160...630	800 aR	100	LC1G630	LR9G630
	800 aR	80		
	800 aR	25		

Overload relay accessories

Mounting and wiring accessories

Description	Reference
Mounting base for alignment of LR9G115-225 with LC1G115-225 ⁽²⁾	LA9G3650
Mounting base for alignment of LR9G500 with LC1G265-330 ⁽²⁾	LA9G3651
Mounting base for alignment of LR9G500 with LC1G400-500 ⁽²⁾	LA9G3652
Mounting base for alignment of LR9G630 with LC1G630-800 ⁽²⁾	LA9G3653
Push-in connection adapter	LA9G82

Front protection cover

Description	Compatible with contactors	Quantity	Reference
Front protection cover ⁽³⁾	LR9G115 / LR9G225	1	LA9G3704
	LR9G500	1	LA9G3705
	LR9G630	1	LA9G3706

⁽²⁾ Used for independent mounting of Overload Relay beneath contactor to align main power pole connections.

⁽³⁾ Used to cover main power connection terminals between contactor and overload with direct mounting option.



TeSys Protect

Giga Electronic overload relays

Product references



PE121733.eps

LAD703●

Remote Reset control device

Description	Quantity	Reference
Remote electrical reset device ⁽¹⁾	1	LAD703● ⁽²⁾
Remote Reset function control by flexible cable (length = 0.5 m)	1	LAD7305

⁽¹⁾ The time for which the coil of remote electrical reset device LAD703● can remain energised depends on its rest time: 1 s pulse duration with 9 s rest time; 5 s pulse duration with 30 s rest time; 10 s pulse duration with 90 s rest time. Maximum pulse duration of 20 s with rest time of 300 s. Minimum pulse time: 200 ms.

⁽²⁾ Reference to be completed by adding the coil voltage code.



PE121732.eps

LAD7305

Standard control circuit voltages

Volts	24	110	220/230
~ 50/60 Hz	B	F	M
Consumption, inrush and sealed: < 100 VA			
---	B	F	M
Consumption, inrush and sealed: < 100 W.			



TeSys Protect

RM1XA magnetic over current relays

Product references



RM1XA●●●

Single-pole, non-latching, over current relays				
With 1 C/O contact block				
	Recommended operating range (motor I _n)	Setting range (trip current)	Maximum continuous current ~ or ☰	Reference
A	0.7...1.15	1.25...4	1.6	RM1XA001
~ or ☰	3...4.6	5...16	6.3	RM1XA006
	7.3...11.5	12.5...40	16	RM1XA016
	18.1...29	32...100	40	RM1XA040
	46.1...72	80...250	100	RM1XA100
	73...115	125...400	160	RM1XA160
	146...230	250...800	315	RM1XA315
	231...360	400 ...1250	500	RM1XA500



Overload relays

TeSys Protect

RM1X magnetic over current relays

Product references



RM1XA3151



ER1XA2M

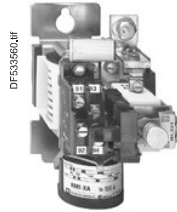

ER1XA2M
mounted on
RM1XA3151

Single-pole, latching, manual reset, over current relays

With 1 C/O contact block

Recommended operating range (motor In)	Setting range (trip current)	Maximum continuous current ~ or ---	Reference
A	A	A	
146...230	250...800	315	RM1XA3151

Accessories (to be ordered separately)

Description	Reference
Electrical reset ⁽¹⁾ (consumption: inrush, sealed: 500 VA, 220 V 50 Hz coil) (fitted to the relay together with a latching contact block)	ER1XA2M

⁽¹⁾ The impulse duration must not exceed 2 seconds within 10 minute intervals.



TeSys Protect

LT3 Thermal protection units

Product references



LT3SE00M



LT3SA00M



LT3SM00M

Protection units

- to be used with PTC thermistor probes
- with thermistor short-circuit detection
- The contact changes state when a rapid rise in temperature above the nominal probe rating is detected.

With automatic reset

Connection	Voltage		Output contact	Reference
Cage connectors	~ 50/60 Hz	115 V	N/C	LT3SE00F
		230 V	N/C	LT3SE00M
---		24 V	N/C	LT3SE00BD

Units with automatic reset and front signalling by LED's (Power-Fault)

Connection	Voltage		Output contact	Reference
Cage connectors	~ 50/60 Hz	115/230 V	N/C + N/O	LT3SA00M
		---	24/48 V	N/C + N/O
	~ 50/60 Hz	24...230 V	2 C/O	LT3SA00MW
	or ---			

Manual reset, on front: Test/Reset pushbutton Power + Fault LED's

Connection	Voltage		Output contact	Reference
Cage connectors	~ 50/60 Hz	400 V	N/C + N/O	LT3SM00V
		24/48 V	N/C + N/O	LT3SM00E
		115/230 V	N/C + N/O	LT3SM00M
---		24/48 V	N/C + N/O	LT3SM00ED
	~ 50/60 Hz	24...230 V	2 C/O	LT3SM00MW
	or ---			



Overload relays

TeSys Protect

PTC⁽¹⁾ thermistor probes for LT3 thermal protection units

Product references

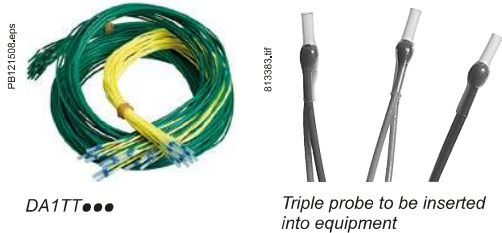

PTC thermistor probes

Description	Nominal Operating Temperature (NOT) ° C	Colour	Sold in lots of	Unit reference
Integrated triple probes	90	Green/green	10	DA1TT090
	110	Brown/brown	10	DA1TT110
	120	Grey/grey	10	DA1TT120
	130	Blue/blue	10	DA1TT130
	140	White/blue	10	DA1TT140
	150	Black/black	10	DA1TT150
	160	Blue/red	10	DA1TT160
Surface probes	170	White/green	10	DA1TT170
	60	White/grey	10	DA1TS060
	70	White/brown	10	DA1TS070
	80	White/white	10	DA1TS080
	90	Green/green	10	DA1TS090
	100	Red/red	10	DA1TS100

Accessories (to be ordered separately)

Mounting accessories

Description	Applicationi	Sold in lots of	Unit reference
Adapter	For fixing on C-rail DZ5 MB	10	RHZ66

Marking accessories

Clip-in markers (maximum of 5 per unit)	Strips of 10 identical numbers (0 to 9)	25	AB1R● ⁽²⁾
	Strips of 10 identical capital letters (A to Z)	25	AB1G● ⁽²⁾

⁽¹⁾ PTC: Positive Temperature Coefficient.

⁽²⁾ When ordering, replace the ● in the reference with the number or letter required.

TeSys Protect

LR97, LT47 Electronic over current relays

Product references



PB111874-eps

LR97D07●●



PB111827-eps

LT4730●●●

LR97D electronic over current relays

Relay setting range	Usable range ⁽¹⁾	For use with contactor ⁽²⁾	Relay supply voltage	Reference ⁽³⁾
A	A			
0.3...1.5	0.3...1.3	LC1 D09...D38	~ 200...240 V	LR97D015M7
			~ 100...120 V	LR97D015F7
			~/~ 24 V	LR97D015B
			~/~ 48 V	LR97D015E
1.2...7	1.2...6	LC1 D09...D38	~ 200...240 V	LR97D07M7
			~ 100...120 V	LR97D07F7
			~/~ 24 V	LR97D07B
			~/~ 48 V	LR97D07E
5...25	5...21	LC1 D09...D38	~ 200...240 V	LR97D25M7
			~ 100...120 V	LR97D25F7
			~/~ 24 V	LR97D25B
			~/~ 48 V	LR97D25E
20...38	20...34	LC1 D25...D38	~ 200...240 V	LR97D38M7
			~ 100...120 V	LR97D38F7
			~/~ 24 V	LR97D38B
			~/~ 48 V	LR97D38E

LT47 electronic over current relays

Relay setting range	Usable range ⁽¹⁾	Relay supply voltage	Reference
A	A		
LT47 relay with manual/electric reset			
0.5...6	0.5...5	~ 200...240 V	LT4706M7S
		~ 100...120 V	LT4706F7S
		~/~ 24 V	LT4706BS
3...30	3...25	~ 200...240 V	LT4730M7S
		~ 100...120 V	LT4730F7S
		~/~ 24 V	LT4730BS
5...60	5...50	~ 200...240 V	LT4760M7S
		~ 100...120 V	LT4760F7S
		~/~ 24 V	LT4760BS
		~/~ 48 V	LT4760ES
LT47 relay with automatic reset			
0.5...6	0.5...5	~ 200...240 V	LT4706M7A
		~/~ 24 V	LT4706BA
3...30	3...25	~ 200...240 V	LT4730M7A
		~ 100...120 V	LT4730F7A
		~/~ 24 V	LT4730BA
		~/~ 48 V	LT4730EA
5...60	5...50	~ 200...240 V	LT4760M7A
		~/~ 24 V	LT4760BA

Accessories (to be ordered separately)

Description	For use with	Sold in lots of	Unit reference
Pre-wiring kits allowing connection of the LR97D relay N/C contact directly to the contactor	LC1 D09...D18	10	LAD7C1
	LC1 D25...D38	10	LAD7C2
Terminal block for clip-on mounting on 35 mm rail (AM1 DP200)	LR97D	1	LAD7B106

(1) To allow adjustment of the tripping sensitivity, see adjustment method (page B11/56).

(2) Please see chapter B8.

(3) If a pre-wiring kit is used, it is no longer possible to electrically wire signalling of tripped status.



Overload relays

TeSys Protect

Thermal and electronic overload relays

Product references

DA1TT090	LR3D03	LR7K0306	LRD08L	LRD3359
DA1TT110	LR3D04	LR7K0308	LRD08L6	LRD3359A66
DA1TT120	LR3D046	LR7K0310	LRD10	LRD3361
DA1TT130	LR3D05	LR7K0312	LRD103	LRD3363
DA1TT140	LR3D056	LR7K0314	LRD106	LRD3365
DA1TT150	LR3D06	LR7K0316	LRD10L	LRD33656
DA1TT160	LR3D066	LR97D015B	LRD10L6	LRD33676
DA1TT170	LR3D07	LR97D015E	LRD12	LRD33696
DPER01	LR3D076	LR97D015F7	LRD123	LRD340
DPER21	LR3D07L	LR97D015M7	LRD126	LRD3406
DPER32	LR3D08	LR97D07B	LRD12L	LRD340L
DPER35	LR3D086	LR97D07E	LRD14	LRD340L6
ER1XA2M	LR3D08L	LR97D07F7	LRD143	LRD35
LA7D03B	LR3D10	LR97D07M7	LRD146	LRD350
LA7D03F	LR3D106	LR97D25B	LRD14L	LRD3503
LA7D03M	LR3D10L	LR97D25E	LRD1508	LRD3506
LA7D03Q	LR3D12	LR97D25F7	LRD1510	LRD350L
LA7D1020	LR3D126	LR97D25M7	LRD1512	LRD356
LA7D1064	LR3D12L	LR97D38B	LRD1514	LRD365
LA7D305	LR3D14	LR97D38E	LRD1516	LRD3653
LA7D3058	LR3D146	LR97D38F7	LRD1521	LRD3656
LA7D3064	LR3D14L	LR97D38M7	LRD1522	LRD365L
LA7D30646	LR3D16	LR9D5367	LRD1530	LRD365L6
LA7D903	LR3D166	LR9D5369	LRD1532	LRD380
LA7K0064	LR3D16L	LR9D5567	LRD16	LRD3803
LA9D730	LR3D21	LR9D5569	LRD163	LRD3806
LA9D91	LR3D216	LR9D67	LRD166	LRD4365
LAD703B	LR3D21L	LR9D69	LRD16L	LRD4367
LAD703E	LR3D22	LR9G115	LRD16L6	LRD4369
LAD703F	LR3D226	LR9G225	LRD21	LRD488C
LAD703M	LR3D22L	LR9G500	LRD213	LT4706BA
LAD703Q	LR3D313	LR9G630	LRD216	LT4706BS
LAD7305	LR3D318	LA9G3650	LRD21L	LT4706F7S
LAD7B105	LR3D32	LA9G3651	LRD21L6	LT4706M7A
LAD7B1056	LR3D325	LA9G3652	LRD22	LT4706M7S
LAD7B106	LR3D326	LA9G3653	LRD223	LT4730BA
LAD7B205	LR3D32L	LA9G82	LRD226	LT4730BS
LAD7C1	LR3D332	LA9G3704	LRD22L	LT4730EA
LAD7C2	LR3D3322	LA9G3705	LRD22L6	LT4730F7A
LR2D3522	LR3D3353	LA9G3706	LRD313	LT4730F7S
LR2D3553	LR3D3355	LRD01	LRD313L	LT4730M7A
LR2D3555	LR3D3363	LRD02	LRD318	LT4730M7S
LR2D3557	LR3D3365	LRD03	LRD318L	LT4760BA
LR2D3559	LR3D340	LRD04	LRD32	LT4760BS
LR2D3561	LR3D35	LRD046	LRD325	LT4760ES
LR2D3563	LR3D350	LRD04L6	LRD3256	LT4760F7S
LR2K0301	LR3D3522	LRD05	LRD325L	LT4760M7A
LR2K0302	LR3D3553	LRD056	LRD326	LT4760M7S
LR2K0303	LR3D3555	LRD05L	LRD32L	RM1XA001
LR2K0304	LR3D3557	LRD06	LRD32L6	RM1XA006
LR2K0305	LR3D3559	LRD063	LRD3312	RM1XA016
LR2K0306	LR3D3561	LRD066	LRD3314	RM1XA040
LR2K0307	LR3D3563	LRD06L	LRD332	RM1XA100
LR2K0308	LR3D365	LRD07	LRD3322	RM1XA160
LR2K0310	LR3D380	LRD073	LRD3323	RM1XA315
LR2K0312	LR3D3803	LRD076	LRD332L	RM1XA3151
LR2K0314	LR3D3806	LRD07L	LRD3353	RM1XA500
LR2K0316	LR3D4365	LRD07L6	LRD3353A66	
LR2K0321	LR3D4367	LRD08	LRD3355	
LR2K0322	LR3D4369	LRD083	LRD3357	
LR3D02	LR7K0305	LRD086	LRD3357A66	

Overload
relays

This document is current.  Click on the product reference to get the most recent availability status (hyperlink to [se.com](https://www.se.com) product datasheet).
If your product variant is no longer available, please consult your distributor or regional sales office.

Technical Data for Designers

Contents

Motor and machine protection	B11/22 to B11/27
TeSys LRK - thermal overload protection:	
> characteristics	B11/28 to B11/29
> dimensions and schemes	B11/30
Deca - thermal overload protection:	
> characteristics	B11/31 to B11/34
> dimensions	B11/35 to B11/37
> schemes	B11/37
Deca - electronic thermal overload protection:	
> characteristics	B11/38 to B11/41
> dimensions	B11/42
> schemes	B11/43
Giga - electronic overload relays:	
> characteristics	B11/44 to B11/46
> dimensions and diagram	B11/47
RM1 - single pole magnetic over current relays:	
> characteristics	B11/48
> dimensions and schemes	B11/49
LT3 - thermistor protection unit:	
> characteristics	B11/50 to B11/53
> dimensions and schemes	B11/54 to B11/55
LR97, LT47 - electronic over current relays:	
> characteristics	B11/56 to B11/59
> dimensions and schemes	B11/60

Introduction

Exceeding the operating limits of an electric motor will lead, eventually, not only to destruction of the motor itself but also of the mechanisms it drives.

This type of load can be the cause of electrical or mechanical faults.

■ **Electrical faults:**

- overvoltage, voltage drop, imbalance and phase failure which cause variations in the current drawn,
- short-circuits which can cause the current to reach levels capable of destroying the load.

■ **Mechanical faults:**

- locked rotor,
- brief or prolonged overload which leads to an increase in the current drawn by the motor, and therefore overheating.

The cost of these faults must take into account loss of production, loss of raw materials, repair of the production tool, poor quality of production and delays in delivery.

These faults can also have dramatic consequences on the safety of persons in direct or indirect contact with the motor.

To prevent these faults, protection measures are necessary. They make it possible to isolate the equipment to be protected from the mains supply by measuring variations in electrical values (voltage, current, etc.).

Each motor starter must therefore have:

■ **short-circuit protection**, to detect and break, as quickly as possible, abnormal currents generally greater than 10 times the rated current (I_n).

■ **overload protection**, to detect increases in current up to about $10 I_n$ and switch off the starter before overheating of the motor and conductors damages the insulation.

This protection is provided by specific devices such as fuses, circuit breakers and thermal overload relays, or by more integrated devices offering several types of protection.

TeSys Protect

Overload relays

Motor and machine protection

Causes, effects and consequences of various faults

There are two types of fault:

- Internal faults within the motor
- External faults: these are located outside the electric motor but their consequences can lead to damage inside the motor.

Faults	Causes	Effects	Consequences on the motor and on the machine
Short-circuit	Contact between several phases, or between one phase and neutral or between several turns of the same phase.	<ul style="list-style-type: none"> ■ Current peak ■ Electrodynamical forces on the conductors 	Destruction of windings
Overvoltage	<ul style="list-style-type: none"> ■ Lightning ■ Electrostatic discharge ■ Operation 	Dielectric breakdown in the windings	Destruction of the windings due to loss of insulation
Phase imbalance and phase failure	<ul style="list-style-type: none"> ■ Opening of a phase ■ Single-phase load upstream of the motor ■ Short-circuit between the turns of the same winding 	<ul style="list-style-type: none"> ■ Reduction of usable torque, efficiency and speed ■ Increase in losses ■ Starting impossible if phase failure 	Overheating ⁽¹⁾
High starting frequency	<ul style="list-style-type: none"> ■ Failure of the automation system ■ Too many manual control operations ■ Numerous fault trips 	High stator and rotor temperature rise due to the frequent start current	Overheating ⁽¹⁾ Consequences on the process
Voltage variations	<ul style="list-style-type: none"> ■ Instability of the mains voltage ■ Connection of heavy loads 	<ul style="list-style-type: none"> ■ Reduction of usable torque ■ Increase in losses 	Overheating ⁽¹⁾
Harmonics	<ul style="list-style-type: none"> ■ Pollution of the mains supply by variable speed drives, inverters, etc... 	<ul style="list-style-type: none"> ■ Reduction of usable torque ■ Increase in losses 	Overheating ⁽¹⁾
Long starting time	<ul style="list-style-type: none"> ■ Resistive torque too high (load too heavy) ■ Voltage drop 	Increase in starting time	Overheating ⁽¹⁾
Jamming	<ul style="list-style-type: none"> ■ Mechanical problem (crusher) ■ Seizures 	Overcurrent	Overheating ⁽¹⁾ Consequences on the process
No-load running	<ul style="list-style-type: none"> ■ Pump running empty ■ Mechanical break in drive to the load 	Drop in current drawn	Consequences on the process
Frequency fluctuations	<ul style="list-style-type: none"> ■ Overload of a supply powered by limited independent sources ■ Faulty alternator speed regulator 	<ul style="list-style-type: none"> ■ Increase in losses ■ Interferes with synchronous devices (clock, recorder, ...) 	–
Overload	<ul style="list-style-type: none"> ■ Increase in resistive torque ■ Voltage drop ■ Drop in power factor 	Increase in current consumption	Overheating ⁽¹⁾
Loss of machine excitation	<ul style="list-style-type: none"> ■ Significant drop in excitation current ■ Break in rotor winding 	<ul style="list-style-type: none"> ■ Increase in active power ■ Drop in power factor 	Significant overheating of rotor and cage
Phase-Earth fault	<ul style="list-style-type: none"> ■ Accidental Phase-Earth contacts ■ Accidental Phase-machine casing contacts (casing connected to earth) 	<ul style="list-style-type: none"> ■ Overvoltage developed in the mains supply ■ Rise in earth potential (safety of persons) 	Consequences on safety of persons

⁽¹⁾ Then, in the longer or shorter term, depending on the seriousness of the fault and/or its frequency, short-circuit and destruction of the windings.

Protection functions

Short-circuit protection

General

A short-circuit results in a very rapid rise in current which can reach several hundred times the value of the operational current. The consequences of a short-circuit are dangerous to both equipment and persons. It is therefore imperative to use protection devices to detect the fault and very quickly break the circuit.

Two types of protection are commonly used:

- fuses (cutout) which break the circuit by melting, which then requires their replacement,
 - magnetic trip circuit breakers, often more simply called "magnetic circuit breakers", which only require re-setting to put them back into service.
- Short-circuit protection can also be built-into multifunction devices such as motor circuit breakers and contactor-breakers.

The main characteristics of short-circuit protection devices are:

- their breaking capacity: this is the highest prospective short-circuit current value that a protection device can break at a given voltage.
- their making capacity: this is the highest current value that the protection device can make at its rated voltage in specified conditions.

The making capacity is equal to k times the breaking capacity.



Fuse carrier
Ref. LS1D32



Switch disconnectors
Ref. GS2N3

Fuses (cutouts)

Fuses provide individual phase protection (single-pole), with a high breaking capacity in a compact size:

- mounted either in fuse carriers,
- or in isolators, replacing the original links or shunt bars.

For motor protection, aM type fuses are used. Their design characteristics allow them to conduct the high magnetising currents that occur when motors are switched on. They are therefore unsuitable for overload protection (unlike gG type fuses). This is why an overload relay must be included in the motor power supply circuit.



Deca Magnetic circuit
breaker
Ref. GV2L



Deca Magnetic circuit
breaker
Ref. GV4LE

Magnetic circuit breakers

These circuit breakers protect installations against short-circuits, within the limit of their breaking capacity.

Magnetic circuit breakers provide omnipole breaking as standard.

For relatively low short-circuit currents, the operation of a circuit breaker is faster than that of fuses.

This protection conforms to standard IEC 60947-2.

The thermal and electrodynamic effects are also limited, therefore ensuring better protection of cables and equipment.

TeSys Protect Overload relays

Motor and machine protection



Deca Thermal overload relay
Ref. LRD08



Current measurement relay
Ref. RM4JA

Protection functions

Overload protection

General

An overload condition is the most frequently encountered fault. The symptoms are a rise in the current drawn by the motor and thermal effects. A rapid return to normal operating conditions is important.

The actual operating conditions (ambient temperature, operating altitude and type of standard duty) are essential to determine the operating values of the motor (power, current) and to be able to select effective overload protection. These operational values are given by the motor manufacturer.

According to the level required, protection can be provided by:

- overload relays and thermal overload relays (bi-metallic or electronic type) which protect motors in the event of:
 - overload, by monitoring the current drawn by each phase,
 - phase imbalance or failure, by their differential mechanism.
- relays with PTC thermistor probes (Positive Temperature Coefficient).
- overtorque relays,
- multifunction relays.

Overload relays

These relays protect motors against overload. They must allow the temporary overload that occurs on starting and must only trip if the starting time is abnormally long.

The overload relay will be selected according to the length of the starting time (tripping class) and the motor rating.

These relays have a thermal memory (except for certain electronic overload relays, indicated by their manufacturers) and can be connected:

- either in series with the load,
- or to current transformers placed in series with the load.

Bi-metallic thermal overload relays

Combined with a contactor, these relays protect the line and the equipment against small and prolonged overloads. They must be protected against strong overcurrent by a circuit breaker or fuses.

These relays may be used on an a.c. or d.c. system and are generally:

- 3-pole,
- compensated, i.e. insensitive to ambient temperature variations,
- with manual or automatic reset,
- graduated with a "motor FLC" scale: allowing direct setting to the full load current as shown on the motor rating plate.

They can also be sensitive to phase failure: this is known as 'differential'. This function conforms to standards IEC 60947-4-1 and 60947-6-2.

This type of relay is extremely reliable and is a relatively low cost device.

Electronic thermal overload relays

Electronic thermal overload relays have the advantage of electronics which allow a more complex thermal image of the motor to be created.

They can be combined with products having complementary functions, such as:

- temperature sensing via PTC probes,
- protection against jamming and overtorque,
- protection against phase reversal,
- earth fault protection,
- protection against no-load running,
- alarm function.

TeSys Protect

Overload relays

Motor and machine protection



Relays for use with thermistor probes
Ref. LT3S



Instantaneous electronic overcurrent relays
Ref. LR97D07



Ultra starter Ref. LUB320 with multifunction control unit Ref. LUCM



Ultra controller Ref. LUTM20BL



T controller Ref. LTMR08MBD

Protection functions *(continued)*

Overload protection *(continued)*

Relays for use with PTC thermistor probes

With direct sensing of the stator windings, these relays can be used to protect motors against:

- overload,
- a rise in ambient temperature,
- a ventilation circuit fault,
- a high starting frequency,
- mechanical shocks, etc.

Overload (or overtorque) relays

These relays protect the drive line in the event of a locked rotor, seizure or mechanical shocks. This is an additional protection.

Unlike thermal overload relays, these relays do not have a thermal memory. They have definite time characteristics (adjustable current threshold and time delay).

The overtorque relay can be used as overload protection for motors with long starting times or very frequent starting (for example, lifting hoists).

Multifunction relays

Overcurrent relays are limited when it is necessary to take into account problems associated with voltage, temperature or special applications. New production or maintenance management needs have prompted manufacturers to offer products which provide not only adaptable protection, but also complete management of the motor and its load.

They incorporate:

- current and voltage sensors (T controllers),
 - hybrid analog and digital electronic technology,
 - the use of communication buses for data exchange and control,
 - powerful motor modelling algorithms,
 - integrated application programs whose parameters can be set.
- These products make it possible to reduce installation and operating costs by reducing maintenance and downtime.

Ultra starters:

The multifunction relay is incorporated in the motor starter.

This solution is very compact with reduced wiring. It is limited to 32 A.

Ultra controllers:

The multifunction relay is separate from the power line and reuses the function blocks from the Ultra solution. It can be used in conjunction with a contactor up to 810 A.

T controllers:

The multifunction relay is separate from the power line and incorporates inputs and outputs. It can be used in conjunction with a contactor up to 810 A.

TeSys Protect

Overload relays

Motor and machine protection

Protection relay selection table					
Relay type	Motor protection		Machine protection	Motor and machine protection	
	Thermal overload relay Ref. LR2K, LRD, LRD3, LR9D ⁽¹⁾ , LR9G	Relays for use with PTC probes Ref. LT3S	Overtorque relays Ref. LR97D, LT47	Ultra controller Ref. LUTM	T controller Ref. LTMR
Causes of overheating	(2)		(2)	(2)	(3)
Slight overload					
Locked rotor					
No-load running					
Supply phase failure			LR97D		
Ventilation fault					With probes
Abnormal temperature rise					With probes
Shaft bearing seizure					With probes
Insulation fault					
Protracted starting time					
Severe duty					With probes
Voltage variation					
Frequency fluctuations					
Loss of machine excitation					

- Ideally suited
- Possible solution
- Not suitable (no protection)

(1) For motor circuit breaker ref. GV2ME.
 (2) Protection based on current.
 (3) Protection based on current and voltage.

TeSys Protect

LRK Thermal overload relay

Characteristics

Environment					
Conforming to standards			IEC/EN 60947-4-1, IEC/EN 60947-5-1, UL 60947-4-1, CSA C22.2 n° 60947-4-1, UL 60947-5-1, CSA C22.2 n° 60947-5-1, GB/T14048.		
Product certifications			UL, CSA, CCC, EAC, CB, UKCA certification		
Degree of protection	Conforming to IEC 60529		Protection against direct finger contact		
Ambient air temperature around the device	Storage	°C	-40...+70		
	For normal operation (IEC 60947)	°C	-20...+55 (without derating)		
	Operating limit	°C	-30...+60 (with derating) ⁽¹⁾		
Maximum operating altitude	Without derating	m	2000		
Operating positions			<p>Vertical axis</p> <p>Without derating</p>	<p>Horizontal axis</p> <p>With derating ⁽¹⁾</p>	
Flame resistance	Conforming to 60695-2-11	°C	850		
Shock resistance, hot state (1/2 sine wave, 11 ms)	Conforming to IEC 60068-2-27, N/C contact		10 gn		
	Conforming to IEC 60068-2-27, N/O contact		10 gn		
Vibration resistance, hot state 5 to 300 Hz	Conforming to IEC 60068-2-6, N/C contact		2 gn		
	Conforming to IEC 60068-2-6, N/O contact		2 gn		
Cabling Screw clamp terminals	Solid cable Flexible cable without cable end Flexible cable with cable end	mm ²	Minimum	Maximum	Maximum to IEC 60947
			1 x 1.5	2 x 4	1 x 4 + 1 x 2.5
			1 x 0.75	2 x 4	2 x 2.5
			1 x 0.34	1 x 1.5 + 1 x 2.5	1 x 1.5 + 1 x 2.5
Tightening torque	Philips head n° 2 - Ø6	N.m	0.8		
Mounting			Directly under the contactor or reversing contactor		
Connections			Made automatically when mounted under the contactor, as follows: <ul style="list-style-type: none"> ■ contactor terminal A2 connected to overload relay terminal 96 on all products, ■ contactor terminal 14 connected to overload relay terminal 95 on products with 3 P + N/O. When using 3 P + N/C, or 4 P contactors, or the N/O auxiliary contact marked 13-14, at a voltage other than the coil voltage, break off the link marked 14.		

Ref.



Auxiliary contact characteristics									
Number of contacts			1 N/C + 1 N/O						
Conventional thermal current		A	6						
Short-circuit protection	Conforming to IEC 60947 gG fuse or circuit breaker GB2CB●●	A	6 max.						
Maximum power of the controlled contactor coils (sealed) (Occasional operating cycles of contact 95-96)	a.c.	V	24	48	110	220/230	400	415/440	600/690
		VA	100	200	400	600	600	600	600
	d.c.	V	24	48	110	220	250	—	—
		W	100	100	50	45	35	—	—
Maximum operational voltage	a.c., category AC-15	V	690						
	d.c., category DC-13	V	250						

(1) Please consult your Regional Sales Office.
 (2) Very low safety voltage.

Overload relays

TeSys Protect

LRK Thermal overload relays

Characteristics

Electrical characteristics of the power circuit

Rated operational voltage (Ue)	Up to	V	690
Rated insulation voltage (Ui)	Conforming to IEC 60947	V	690
	Conforming to UL 60947-4-1, CSA C22.2 n° 60947-4-1	V	600
Rated impulse withstand voltage (Uimp)		kV	6
Frequency limits of the operational current		Hz	Up to 400
Power dissipated per pole		W	2

Operating characteristics

Tripping threshold	Conforming to IEC 60947-4-1	A	1.14 ±0.06 Ir
Sensitivity to phase failure	Conforming to IEC 60947		Yes
Reset	Manual or automatic		Selected by means of a lockable and sealable switch on the front of the relay
Signalling	On front of relay		Trip indicator
Reset-Stop function			Pressing the Reset-Stop button: - actuates the N/C contact - has no effect on the N/O contact
Test function	By pushbutton		Pressing the Test button enables: - checking of the control circuit wiring - simulation of overload tripping (actuation of both N/C and N/O contacts, and of the trip indicator)
Short-circuit protection and coordination			See pages A5/12 and A5/30

Tripping curves

Average operating time related to multiples of the current setting (Class 10 A)

Balanced 3-phase operation, from cold state

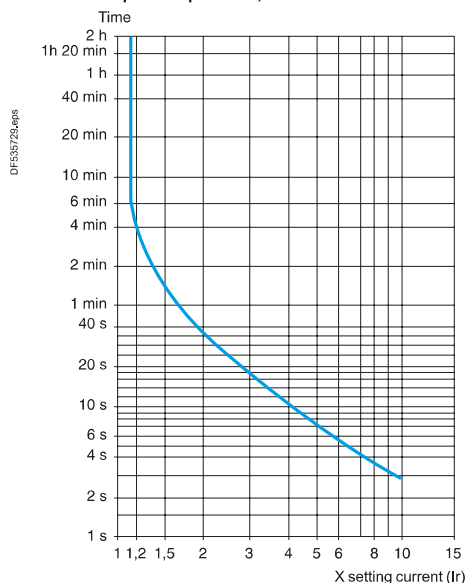

Balanced operation with 2 phases only, from cold state

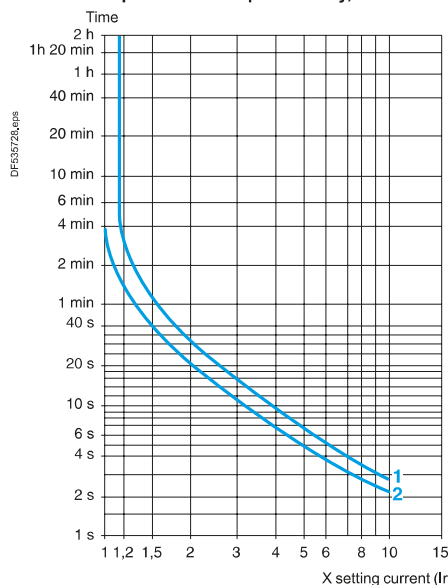

Setting: at lower end of scale

Setting: at upper end of scale

Ref.



Overload relays

TeSys Protect

LRK Thermal overload relays

Dimensions, mounting, schemes

Dimensions, mounting

LR2K

Direct mounting beneath the contactor

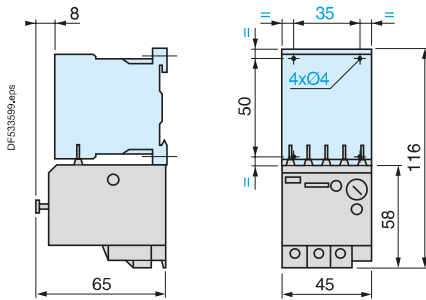

Separate mounting with terminal block LA7 K0064 on 35 mm \hookrightarrow rail (AM1DP200 or AM1DE200)

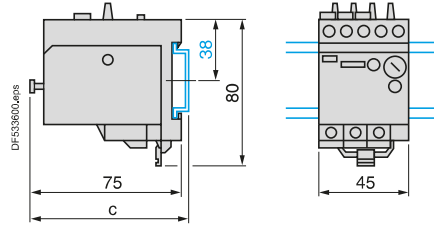

AM1	c
DP200	78,5
DE200	86

Schemes

LR2K

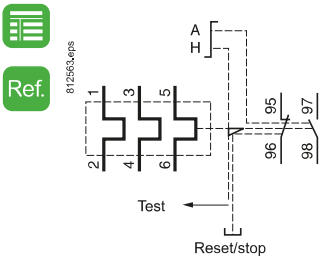

LR2K + LC0K

Pre-wiring scheme

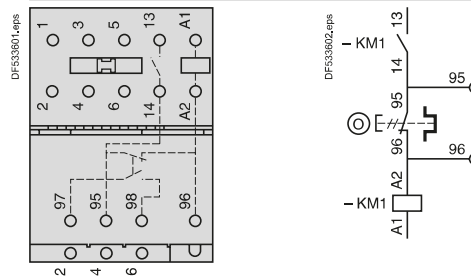

LR7K

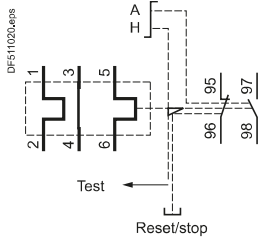

Note: If pre-wiring is not required, break off the 2 links located on the thermal overload relay.

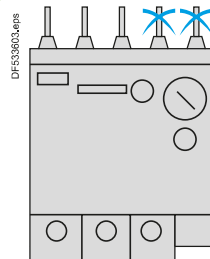

TeSys Protect

Deca Thermal overload relays

Characteristics



Ref. LRD08



Ref. LRD05L...32L



Ref. LRD365

EverLink®



Ref. LRD33●●

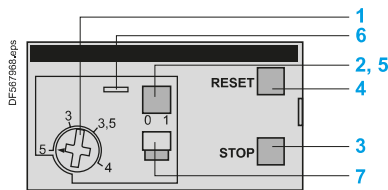

Ref. LRD01...35, LRD05L...32L
LRD313...LRD365

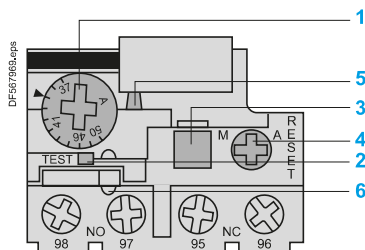

Ref. LRD3361...4369, LR2 D3561...3563

Introduction

3-pole Deca thermal overload relays are designed to protect a.c. circuits and motors against:

- overloads
- phase failure
- excessively long starting times
- prolonged stalled rotor condition.

Power connection

Product references LRD01 to LRD35

LRD01 to 35 relays are designed for connection by screw clamp terminals. They can be supplied for connection by spring terminals or by lugs ⁽¹⁾.

Product references LRD04 to LRD32L

These relays are designed for connection by screw clamp terminals. They can be supplied for connection by lugs ⁽¹⁾.

Product references LRD313 to LRD380

These relays are for connection by BTR screw connectors (hexagon socket head). The screws are tightened by means of a size 4, insulated Allen key.

This type of connection uses the **EverLink®** system with creep compensation ⁽²⁾ (Schneider Electric patent).

This technique makes it possible to achieve accurate and durable tightening torque.

These relays are also available for connection by lugs ⁽¹⁾.

Product references LRD3361 to 4369, LR2D3561 to D3563

Product references LRD3361 to 4369 and LR2D3561 to D3563 relays are designed for connection by screw clamp terminals. They can be supplied for connection by lugs ⁽¹⁾.

Description

Deca 3-pole thermal overload relays are designed to protect a.c. circuits and motors against overloads, phase failure, long starting times and prolonged stalling of the motor.

- 1 Adjustment dial Ir.
- 2 Test button.
Operation of the Test button allows:
 - checking of control circuit wiring,
 - simulation of relay tripping (actuates both the N/O and N/C contacts).
- 3 Stop button. Actuates the N/C contact; does not affect the N/O contact.
- 4 Reset button.
- 5 Trip indicator.
- 6 Setting locked by sealing the cover.
- 7 Selector for manual or automatic reset.

Product references LRD01 to 35, LRD05L to 32L and LRD313 to LRD380 relays are supplied with the selector in the manual position, protected by a cover. Deliberate action is required to move it to the automatic position.

⁽¹⁾ Connection by lugs meets the requirements of certain Asian markets and is suitable for applications subject to strong vibration, such as railway transport.

⁽²⁾ Creep: normal crushing phenomenon of copper conductors, that is accentuated over time.

TeSys Protect

Deca Thermal overload relays

Characteristics

Environment			
Conforming to standards			IEC/EN 60947-4-1, IEC/EN 60947-5-1, UL 60947-4-1, CSA C22.2 n° 60947-4-1, UL 60947-5-1, CSA C22.2 n° 60947-5-1, EN 50495 ⁽¹⁾ , GB/T 14048.4, GB/T 14048.5
Product certifications			UL ⁽²⁾ , CSA ⁽²⁾ , UKCA IEC, CCC ⁽³⁾ , EAC, ATEX ⁽¹⁾ ABS, BV ⁽⁴⁾ , DNV-GL ⁽⁵⁾ , LRoS ⁽⁶⁾ , RINA ⁽⁷⁾ , RMRS ⁽⁸⁾ , EU RO Mutual recognition ⁽⁹⁾
Degree of protection (front face)	Conforming to IEC 60529		Protection against direct finger contact IP20
Climatic withstand			Conforming to IACS E10
Ambient air temperature around the device	Storage	°C	-60...+70
	Normal operation, without derating (IEC 60947-4-1)	°C	-20...+60
	Minimum /maximum operating temperatures (with derating)	°C	-20...+70
Operating positions without derating	In relation to normal vertical mounting plane		Any position. When mounting on a vertical rail, use a stop.
Flame resistance	Conforming to 60695-2-11	°C	850
Shock resistance	Permissible acceleration conforming to IEC 60068-2-27		15 gn - 11 ms
Vibration resistance ⁽¹⁰⁾	Permissible acceleration conforming to IEC 60068-2-6		6 gn except LRD05L...LRD32L: 3 gn
Dielectric strength at 50 Hz	Conforming to IEC 60947-1	kV	1.89 (product Ui 690 V), 2.2 (product Ui 1000 V)
Impulse withstand voltage	Conforming to IEC 60947-1	kV	6

Electrical characteristics of power circuit											
Relay type		LRD01 ...16, LR3D02 ...16	LRD05L ...32L	LRD21 ...35, LR3D21 ...35	LRD313 ...365 LR3D 313 ...38	LRD313L ...365L	LRD3322 ...33696 LR3D3322 ... 33696	LR2D 3522 ... 3563	LRD 4365 ... 4369		
Tripping class	Conforming to UL 60947-4-1, IEC 60947-4-1	10 A	20	10 A	10 A	20	10 A	20	10 A		
Rated insulation voltage (Ui)	Conforming to IEC 60947-4-1	V						690		1000 ⁽¹¹⁾	
	Conforming to UL, CSA	V						600		600 except LRD 4369	
Rated impulse withstand voltage (Uimp)		kV									6
Rated operational voltage (Ue)		V									690
Frequency limits	Of the operating current	Hz									0...400
Setting range	Depending on model	A	0.1...13	0.63...32	12...38	9...80	9...65	17...140	17...80	80...140	

Auxiliary contact characteristics			
Conventional thermal current		A	5
Max. sealed consumption of the operating coils of controlled contactors (Occasional operating cycles of contact 95-96)	a.c. supply, AC-15	V	120 240 380 480 500 600
	d.c. supply, DC-13	A	3 1.5 0.95 0.75 0.72 0.12
		V	125 250 440
		A	0.22 0.1 0.06
Protection against short-circuits	By gG, BS fuses. Maximum rating or by GB2	A	4

⁽¹⁾ For relays LRD01 to LRD380, LRD3322 to LRD3365, LRD04L to LRD32L, LRD4365 to LRD4369, LRD33656 to LRD33696.

⁽²⁾ Except for relays LRD4369.

⁽³⁾ CCC: Except for LRD/LR3D04L to LRD/LR3D32L, LR2D3522 to LR2D3563.

⁽⁴⁾ BV: except for LRD/LR3D04L to LRD/LR3D32L, LRD/LR3D313 to LRD/LR3D380.

⁽⁵⁾ DNV-GL: except for LRD04L to LRD32L.

⁽⁶⁾ LRoS: except for LRD/LR3D04L to LRD/LR3D32L, LRD/LR3D380.

⁽⁷⁾ RINA: for LRD/LR3D01 to LRD/LR3D35.

⁽⁸⁾ RMRS: for LRD/LR3D313 to LRD/LR3D380.

⁽⁹⁾ EU RO Mutual Recognition: for LRD/LR3D313 to LRD/LR3D380, LRD313L to LRD365L.

⁽¹⁰⁾ In case of vibration above 3gn on Deca Green contactor directly mounted with LRD, it is recommended to mount the devices separately by screws on metal plate.

⁽¹¹⁾ 750 V for LRD33656, LRD33676, LRD33696.

Ref.



Overload relays

TeSys Protect

Deca Thermal overload relays

Characteristics

Power circuit connection characteristics

Relay type		LRD01 ...16, LR3D01 ...16	LRD04L ...21L	LRD22L ...32L	LRD21 ...35, LR3D21 ...35	LRD 313 ...365 LR3D 313 ...380	LRD 313L ...365L	LRD 3322 ...33696 LR3D 3322 ... 33696	LR2D 35223563	LRD 4365 ...4369
Connection to screw clamp terminals										
Flexible cable without cable end	1 conductor	mm ² 1.5...10			1.5...10	1...35	1...35	4...35		4...50
Flexible cable with cable end	1 conductor	mm ² 1...4		1...6	1...6 except LRD21: 1...4	1...35	1...35	4...35		4...35
Solid cable without cable end	1 conductor	mm ² 1...6		1.5...10	1.5/10 except LRD21: 1/6	1...35	1...35	4...35		4...50
Tightening torque		N.m 1.7		2.5	2.5	1...25: 5 35: 8	1...25: 5 35: 8	9	9	9
Connection to spring terminals (Min/max c.s.a.) (except LRD04L...LRD32L)										
Flexible cable without cable end	1 conductor	mm ² 1.5...4		-	1.5...4	-	-	-	-	-
Flexible cable with cable end	1 conductor	mm ² 1.5...4		-	1.5...4	-	-	-	-	-

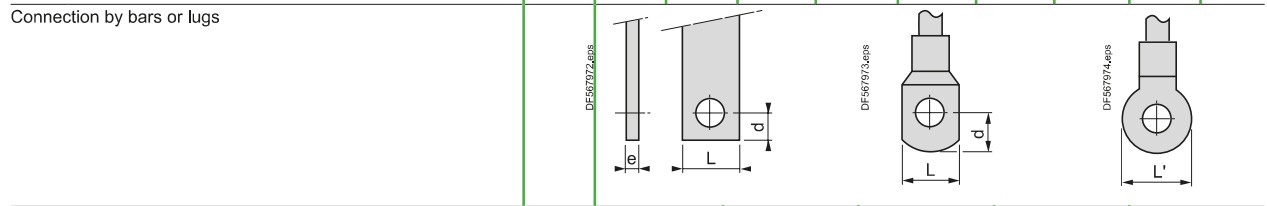

Relay type		LRD016...166 LRD04L6 ... 16L6	LRD216...356 LRD21L6 ... 32L6	LRD3136 ... 3806	LRD313L6 ... 365L6	LRD3322A66 ... 3365A66
Pitch	Without spreaders	mm 14.5	17.5	17.5	17.5	21.5
Bars or cables with lugs	e	mm ≤ 6	≤ 6	≤ 6	≤ 6	≤ 6
	L	mm ≤ 8	≤ 8	≤ 13.5	≤ 13.5	≤ 16
	L'	mm ≤ 9.5	≤ 9.5	≤ 16.5	≤ 16.5	≤ 16
	d	mm ≤ 7	≤ 7	≤ 10	≤ 10	≤ 12
Screws		M4	M4	M6	M6	M10
	Tightening torque	N.m 1.7	2.5	6	6	11.3

Control circuit connection characteristics

Connection to screw clamp terminals or spring terminals

Bare cables

Relay type		LRD01 ...16, LR3D01 ...16	LRD04L ...21L	LRD22L ...32L	LRD21 ...35, LR3D21 ...35	LRD 313 ...365 LR3D 313 ...380	LRD 313L ...365L	LRD3322 ...33696 LR3D 3322 ... 33696	LR2D 3522 ... 3563	LRD 4365 ...4369
Connection to screw clamp terminals ⁽¹⁾	Solid cable without cable end	mm ² 2 x 1...2.5								
	Flexible cable without cable end	mm ² 2 x 1...2.5								
	Flexible cable with cable end	mm ² 2 x 1...2.5								
Tightening torque		N.m 1.7								
Connection to spring terminals (Min/max c.s.a.) (except LRD04L...LRD32L)	Solid cable	mm ² 1...2.5			1...2.5					-
	Flexible cable without cable end	mm ² 1...2.5			1...2.5					-

(1) For relays LRD313 to 380: BTR hexagon socket head screws, EverLink® system. In accordance with local electrical wiring regulations, a size 4 insulated Allen key must be used (reference LADALLEN4, see page B8/42).



Overload relays

TeSys Protect

Deca Thermal overload relays

Characteristics

Operating characteristics

Relay type	LRD01 ...16, LR3D02 ...16	LRD04L... LRD32L	LRD21 ...35, LR3D21 ...35	LRD313 ...365 LR3D 313 ...380	LRD313L ...365L	LRD3322 ...33696 LR3D3322 ...33696	LR2D 3522 ... 3563	LRD 4365 ...4369
Temperature compensation	°C		-20...+60					
Tripping threshold	Conforming to IEC 60947-4-1		A		1.14 ±0.06 I _r			
Sensitivity to phase failure	Tripping current 130 % of I _r on two phases, the third phase at 0.							

Tripping curves

Average operating time related to multiples of the setting current

LRD01 to LRD35, LR2D and LRD3322 to LRD4369

LRD04L to LRD32L and LR2D3522 to LR2D3563

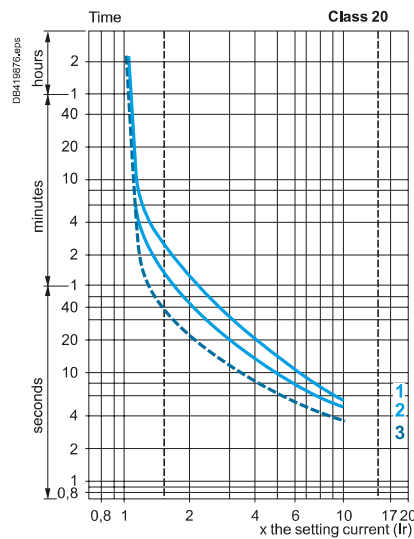
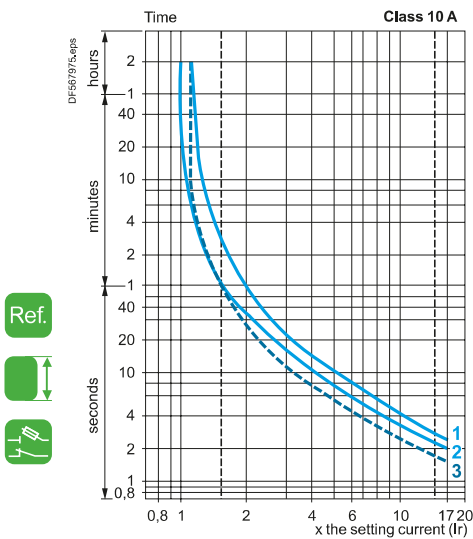

LRD313 to LRD380

LRD313L to LRD365L

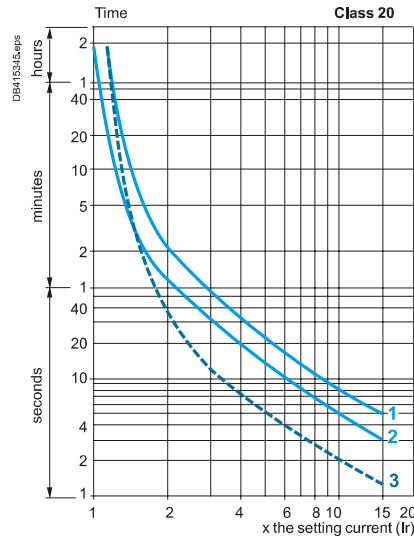
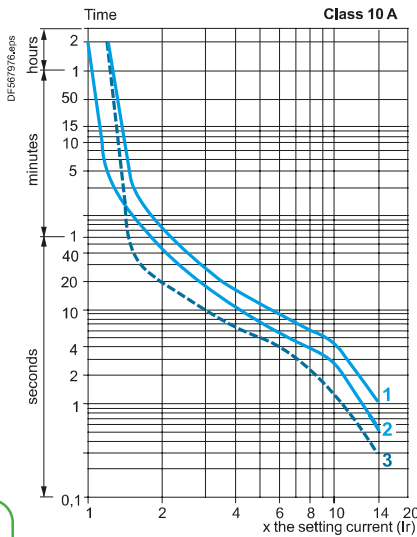

Overload relays

- 1 Balanced operation, 3-phase, without prior current flow (cold state).
- 2 2-phase operation, without prior current flow (cold state).
- 3 Balanced operation, 3-phase, after a long period at the set current (hot state).

TeSys Protect

Deca Thermal overload relays

Dimensions, mounting

LRD01...35 ⁽¹⁾

Direct mounting beneath contactors with screw clamp connections

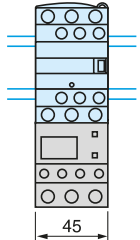
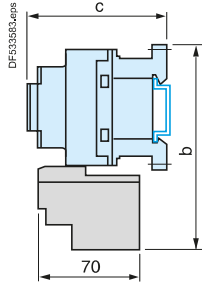

LRD04...32L ⁽¹⁾

Direct mounting beneath contactors with screw clamp connections

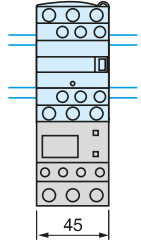
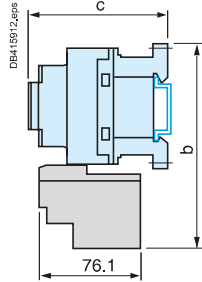

LRD063...223

Direct mounting beneath contactors with spring terminal connections

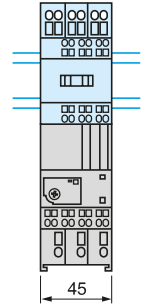
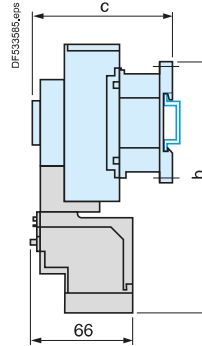

LC1	D09...D18	D25...D38
b	123	137
c	See pages B11/32 and B8/97	

LC1	D09...D18	D25...D38
b	123	137
c	See pages B11/32 and B8/97	

LC1	D093...D253
b	168
c	See pages B11/32 and B8/97

LRD313...380 ⁽¹⁾

Direct mounting beneath contactors LC1D40A...D80A with screw clamp connections or EverLink® connectors

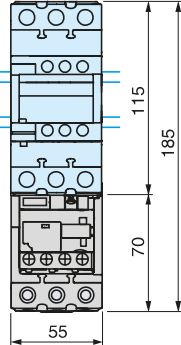
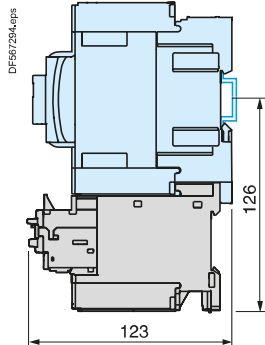

LRD3256...3806 ⁽¹⁾

Direct mounting beneath contactors LC1D40A6...D80A6 with lugs

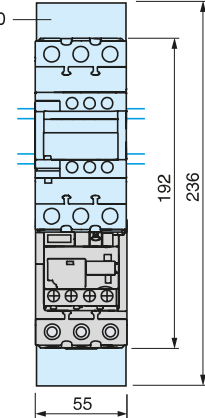
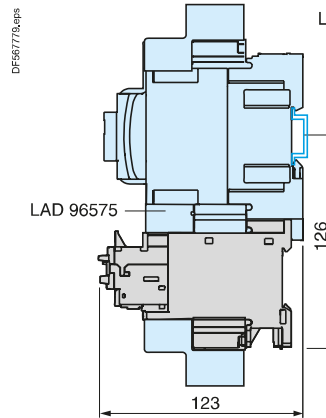

LRD33...^{●●●}

Direct mounting beneath contactors LC1D80...D95

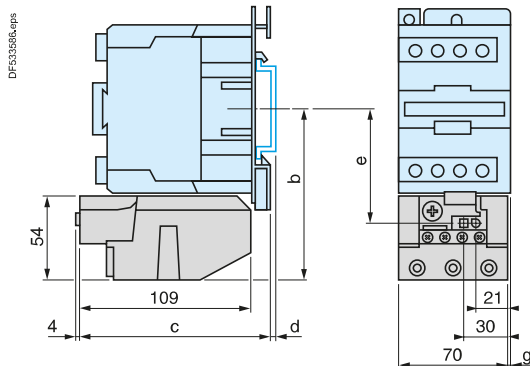

AM1	DL201	DL200
d	7	17

	Control circuit AC				
	b	c	e	g (tri)	g (tetra)
LC1D80	115.5	124	76.9	9.5	22
LC1D95	115.5	124	76.9	9.5	-
Control circuit DC					
LC1D80, D95	115.5	179.4	76.9	9.5	22

⁽¹⁾ In case of vibration above 3 gn on Deca Green contactor directly mounted with LRD, it is recommended do mount the devices separately by screws on metal plate.

TeSys Protect

Deca Thermal overload relays

Dimensions, mounting

LRD4●●●

Direct mounting beneath contactors LC1D115 and D150

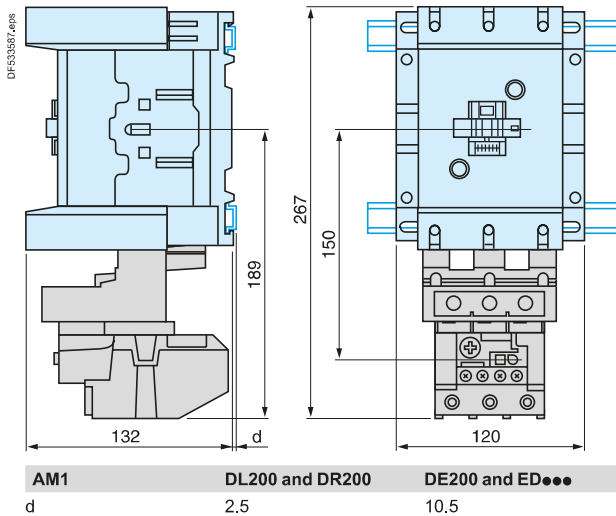

LRD01...35

Independent mounting on 50 mm centres or on rail AM1DP200 or DE200

Independent mounting on 110 mm centres

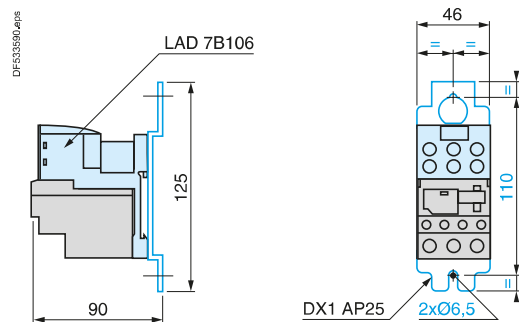
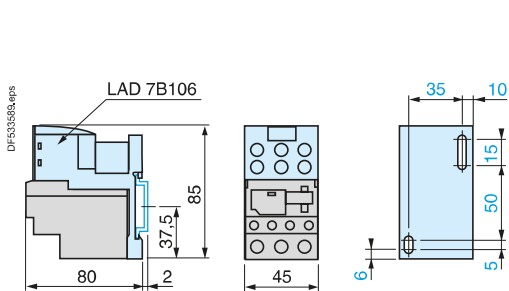

LRD313...380

Mounting on rail AM1D●200 or ED200
With terminal block LAD96560

Panel mounting
Outgoing terminal block
not shown

Mounted on plate AM1P

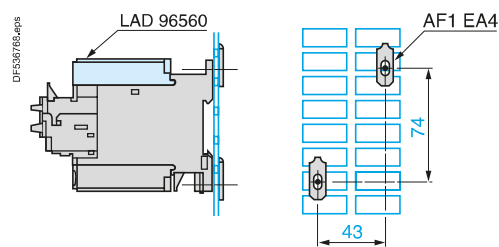
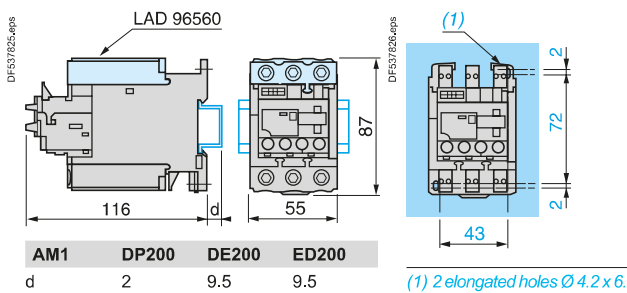

LRD01...35 and LRD313...380

Remote tripping or electrical reset

Overload relays

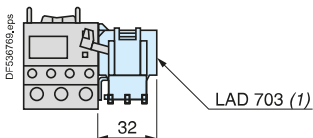

(1) Can only be mounted on RH side of relay LRD01...35 and LRD313...380.

TeSys Protect

Deca Thermal overload relays

Dimensions, mounting and schemes

LRD04L...32L

Independent mounting on 50 mm centres or on rail AM1DP200 or DE200

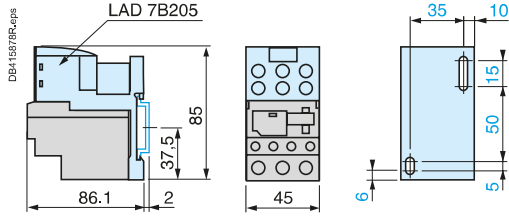

	AM1	DP200	DE200
d	2	9.5	

Independent mounting on 110 mm centres

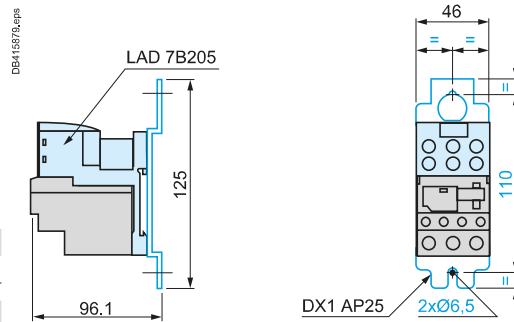

Remote tripping or electrical reset

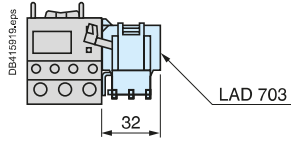

(1) Can be mounted on RH or LH side of relay LR2D15.

LRD3... and LR2D35...

Independent mounting on 50 mm centres or on rail AM1DP200 or DE200

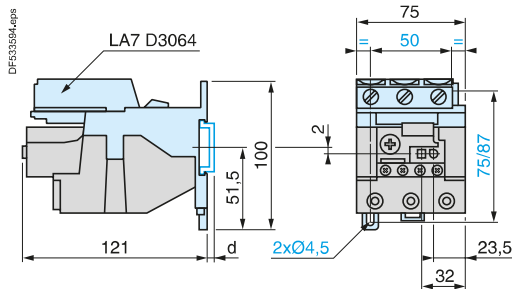

	AM1	DP200	DE200
d	2	9.5	

LRD3..., LR2D35... and LR9D

Remote tripping or electrical reset

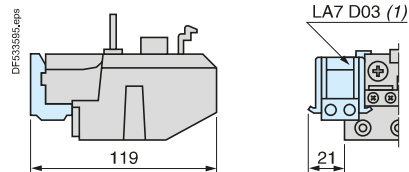

(1) Can be mounted on RH or LH side of relay LRD3..., LR2D35... or LR9D.

LRD3...

Adapter for door mounted operator

LA7D1020

Stop

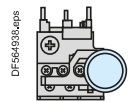

Reset

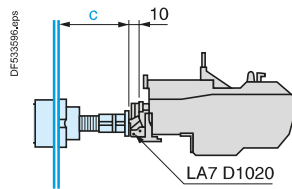
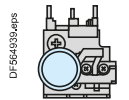

c: adjustable from 17 to 120 mm

LRD, LRD313...380, LRD04...32L

"Reset" by flexible cable

LA7D305 and LAD7305

Mounting with cable straight

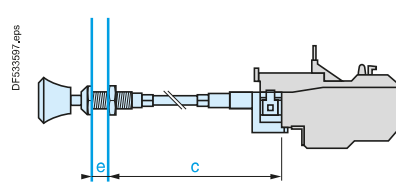

e: up to 20 mm / c: up to 550 mm

Mounting with cable bent

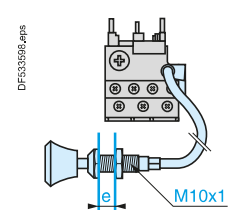

LRD..., LRD3... and LR2D...

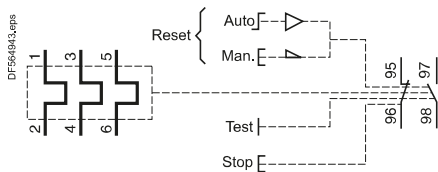

Pre-wiring kit LAD7C1, LAD7C2

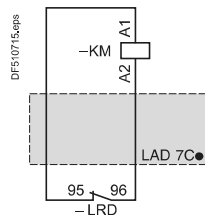

Characteristics:
pages B11/31 to B11/34

References:
pages B11/4 to B11/7

TeSys Protect

Deca Electronic overload relays

Characteristics

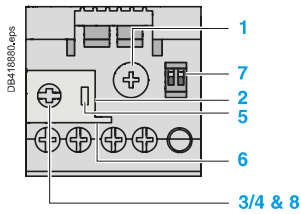

LR9D01...32

Product references LR9D01, 02, 08 and 32

These self-powered electronic thermal overload relays are designed for direct mounting to contactors LC1D09 through LC1D38.

In addition to the protection provided by the Deca thermal overload relays (see page B11/31), they offer the following additional features:

- protection against phase imbalance
- choice of starting class
- protection of unbalanced circuits
- protection of single-phase circuits

- 1 Adjustment dial Ir.
- 2 Test button.
- 3 Stop button.
- 4 Reset button.
- 5 Trip indicator.
- 6 Setting locked by sealing the cover.
- 7 Class 5/10/20/30 dials.
- 8 Reset mode selector.

Environment

Relay type		LR9D01, 02, 08, 32	
Conforming to standards		IEC/EN 60947-4-1, IEC/EN 60947-5-1, UL 60947-4-1, CSA C22.2 n° 60947-4-1, UL 60947-5-1, CSA C22.2 n° 60947-5-1, GB/T 14048.4	
Product certifications		CCC, CSA, UL, CB, UKCA certification	
Degree of protection	Conforming to IEC 60529 and VDE 0106	IP 20 on front panel	
Ambient air temperature around the device (Conforming to IEC 60255-8)	Storage	°C	-55 to +80
	Normal operation	°C	-25 to +70
Maximum operating altitude	Without derating	m	2000
Operating positions without derating	In relation to normal vertical mounting plane	Any position	
Shock resistance	Permissible acceleration conforming to IEC 60068-2-27	15 g (11ms)	
Vibration resistance	Permissible acceleration conforming to IEC 60068-2-6	6 g (10-150 Hz)	
Dielectric strength at 50 Hz	Conforming to IEC 60947-4-1	kV	6
Surge withstand, common mode	Conforming to IEC 61000-4-5	kV	2
Resistance to electrostatic discharge	Conforming to IEC 61000-4-2	kV	8
Immunity to radiated radio-frequency disturbances	Conforming to IEC 61000-4-3 and NF C 46-022	V/m	10
Immunity to fast transient currents	Conforming to IEC 61000-4-4	kV	2
Electromagnetic compatibility	Draft EN 50081-1 and 2, EN 50082-2	Meets requirements	

Electrical characteristics of auxiliary contacts

Conventional thermal current		A	5					
Max. sealed consumption of the operating coils of controlled contactors (Occasional operating cycles of contact 95-96)	a.c. supply, AC-15	V	24	48	110	220	380	600
		VA	100	200	400	600	600	600
	d.c. supply, DC-13	V	24	48	110	220	–	–
		W	100	100	50	45	–	–
Protection against short-circuits	By gG or BS fuses or by circuit breaker GB2	A	5					
Cabling	1 or 2 conductors	mm ² (AWG)	1 to 2.5 (18 to 14)					
Flexible cable without cable end	Tightening torque	Nm (lb-in)	0.8 (7)					

TeSys Protect

Deca Electronic overload relays

Characteristics

Electrical characteristics of power circuit

Relay type		LR9D01	LR9D02	LR9D08	LR9D32	
Tripping class	Conforming to IEC/EN 60947-4-1	5, 10, 20, 30				
	Conforming to UL 60947-4-1, CSA C22.2 n° 60947-4-1	10, 20, 30				
Rated insulation voltage (Ui)	Conforming to IEC 60947-4-1	V AC	1000			
Rated operational voltage (Ue)	Conforming to IEC 60947-4-1	V AC	690			
	Conforming to UL/CSA	V AC	600			
Rated impulse withstand voltage		kV	6			
Frequency limits	Of the operating current	Hz	50...60			
Setting range		A	0.1...0.5	0.4...2	1.6...8	6.4...32
Power circuit connections	Wire size - 1 or 2 conductors	mm ² (AWG)	1 to 16 (14 to 6)			
	Tightening torque	Nm (lb-in)	3.1 (28)			

Operating characteristics

Consumption		mW	< 300		
Tripping thresholds	Conforming to IEC 60947-4-1	A	1.25 In		
Sensitivity to phase unbalance	Conforming to IEC 60947-4-1		Phase difference > 40%, tripping in 3 s		
Current setting ratio			5:1		
Automatic reset time		min.	1.5...4		

LR9D01, 02, 08, 32 tripping curves

Class 5 Trip curve

Tripping time in seconds

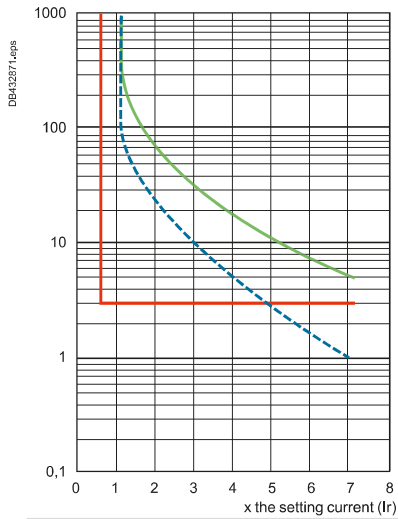

— Cold status
- - Hot status
— Phase low and Phase unbalance

Class 10 Trip curve

Tripping time in seconds

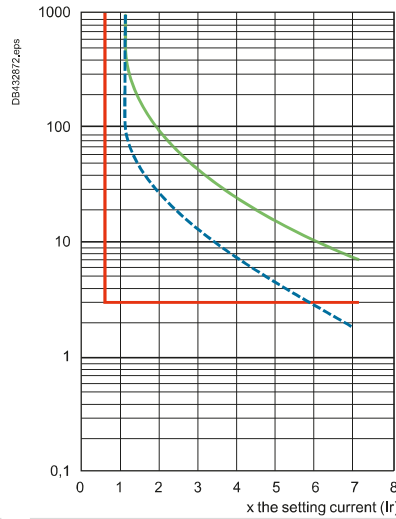

— Cold status
- - Hot status
— Phase low and Phase unbalance

Class 20 Trip curve

Tripping time in seconds

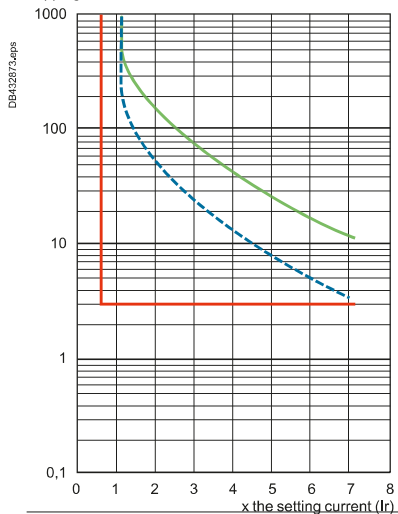

— Cold status
- - Hot status
— Phase low and Phase unbalance

Class 30 Trip curve

Tripping time in seconds

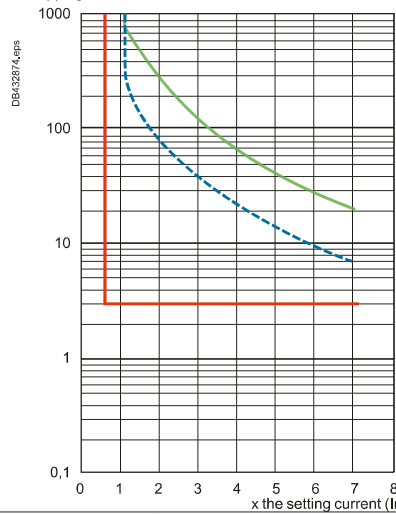

— Cold status
- - Hot status
— Phase low and Phase unbalance

References:
page B11/10

Dimensions, mounting:
page B11/42

Schemes:
page B11/43

Ref.



Overload
relays

TeSys Protect

Deca Electronic overload relays

Characteristics

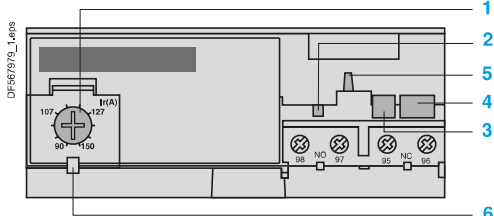

LR9D5367...D5569

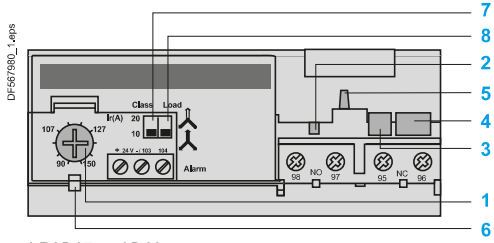

LR9D67 and D69

Description: LR9D5367...LR9D5569, LR9D67, LR9D69

These electronic thermal overload relays are designed for use with contactors LC1D115 and D150.

In addition to the protection provided by Deca thermal overload relays (see page B11/31), they offer the following special features:

- protection against phase imbalance
- choice of starting class
- protection of unbalanced circuits
- protection of single-phase circuits
- alarm function to avoid tripping by load shedding.

- 1 Adjustment dial I_r .
- 2 Test button.
- 3 Stop button.
- 4 Reset button.
- 5 Trip indicator.
- 6 Setting locked by sealing the cover.
- 7 Class 10/class 20 selector switch.
- 8 Selector for balanced load /unbalanced load

Environment

Relay type		LR9D5367...LR9D5569, LR9D67, LR9D69	
Conforming to standards		IEC/EN 60947-4-1, IEC/EN 60947-5-1, UL 60947-4-1, CSA C22.2 n° 60947-4-1, UL 60947-5-1, CSA C22.2 n° 60947-5-1, GB/T 14048.4	
Product certifications		UL, CSA, CCC, ABS, BV, DNV-GL, UKCA	
Degree of protection	Conforming to IEC 60529	IP 20 on front panel with protective covers LA9D11570● or D11560●	
Climatic withstand		according to IACS E10	
Ambient air temperature around the device (Conforming to IEC 60255-8)	Storage	°C	- 40...+ 85
	Normal operation	°C	- 20...+ 55 ⁽¹⁾
Maximum operating altitude	Without derating	m	2000
Operating positions without derating	In relation to normal vertical mounting plane		Any position
Shock resistance	Permissible acceleration conforming to IEC60028-2-27		13 gn - 11 ms
Vibration resistance	Permissible acceleration conforming to IEC 60068-2-6		2 gn - 5...300 Hz
Dielectric strength at 50 Hz	Conforming to IEC 60947-4-1	kV	6
Surge withstand	Conforming to IEC 61000-4-5	kV	6
Resistance to electrostatic discharge	Conforming to IEC 61000-4-2	kV	8
Immunity to radiated radio-frequency disturbances	Conforming to IEC 61000-4-3	V/m	10
Immunity to fast transient currents	Conforming to IEC 61000-4-4	kV	2
Electromagnetic compatibility	EN 50081-1 and 2, EN 50082-2		Meets requirements

Electrical characteristics of auxiliary contacts

Conventional thermal current		A	5					
Max. sealed consumption of the operating coils of controlled contactors (Occasional operating cycles of contact 95-96)	a.c. supply	V	24	48	110	220	380	600
		VA	100	200	400	600	600	600
	d.c. supply	V	24	48	110	220	440	-
		W	100	100	50	45	25	-
Protection against short-circuits	By gG or BS fuses or by circuit breaker GB2	A	5					
Cabling Flexible cable without cable end	1 or 2 conductors	mm ²	Minimum c.s.a.: 1 Maximum c.s.a.: 2.5					
		Tightening torque	Nm	1.2				

(1) For operating temperatures up to 70 °C, please consult your Regional Sales Office.

Ref.



Overload relays

TeSys Protect

Deca Electronic overload relays

Characteristics

Electrical characteristics of power circuit

Relay type		LR9D5367...LR9D5569, LR9D67, LR9D69	
Tripping class	Conforming to IEC/EN 60947-4-1, UL 60947-4-1, CSA C22.2 n° 60947-4-1		10 or 20
Rated insulation voltage (Ui)	Conforming to IEC 60947-4-1	V	1000
	Conforming to UL, CSA	V	600
Rated impulse withstand voltage (Uimp)		kV	8
Frequency limits	Of the operating current	Hz	50...60 ⁽¹⁾
Setting range	Depending on model	A	60...150
Power circuit connections	Width of terminal lug	mm	20
	Clamping screw		M8
	Tightening torque	N.m	18

Operating characteristics

Temperature compensation		°C	- 20...+70
Tripping thresholds	Conforming to IEC 60947-4-1		
	Alarm	A	1.05 ±0.06 In
	Trip	A	1.12 ±0.06 In
Sensitivity to phase failure	Conforming to IEC 60947-4-1		Tripping in 4 s ±20 % in the event of phase failure

Alarm circuit characteristics

Rated supply voltage	d.c. supply	V	24
Supply voltage limits		V	17...32
Current consumption	No-load	mA	≤ 5
Switching capacity		mA	0...150
Protection	Short-circuit and overload		Self protected
Voltage drop	Closed state	V	≤ 2,5
Cabling	Flexible cable without cable end	mm ²	0.5...1.5
Tightening torque		N.m	0.45

⁽¹⁾ For other frequencies and for applications involving the use of these overload relays with soft starters or variable speed drives, please consult your Regional Sales Office.

LR9D5367...LR9D5569, LR9D67, LR9D69 tripping curves

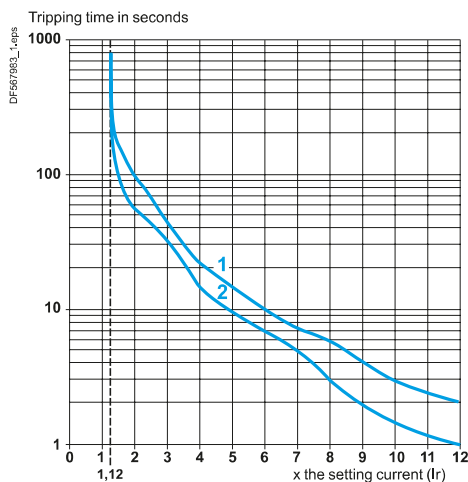

Average operating time related to multiples of the setting current

- 1 Cold state curve
- 2 Hot state curve



Overload relays

TeSys Protect

Deca Electronic overload relays

Dimensions, mounting

LR9D01, 02, 08, 32

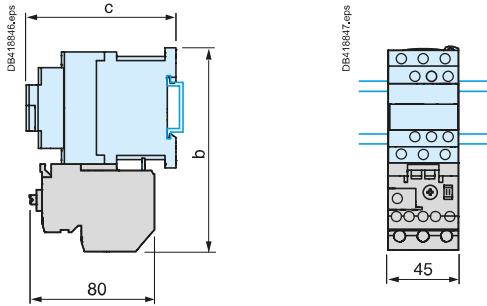

LC1	D09...D18	D25...D38
b	130	140
c	See pages B8/65 and B8/66	

LR9D01...32

Ref.

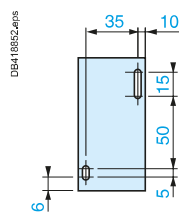
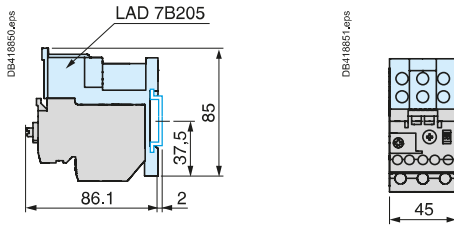

LR9D53●●, LR9D55●●, LR9D67, LR9D69

Direct mounting beneath contactors LC 1D115 and D150

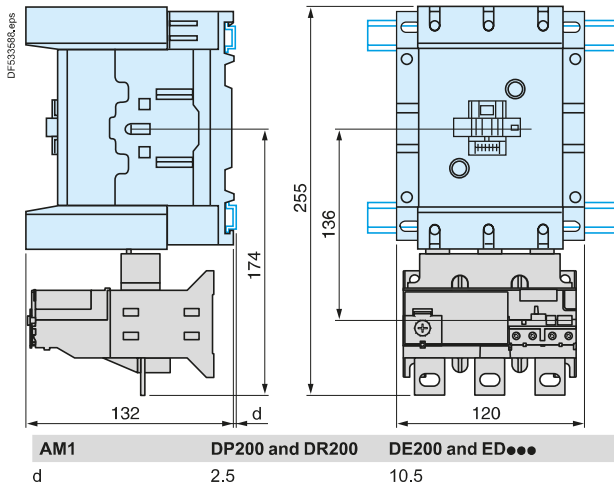

LR9D

"Reset" by flexible cable

LA7D305 and LAD7305

Mounting with cable straight

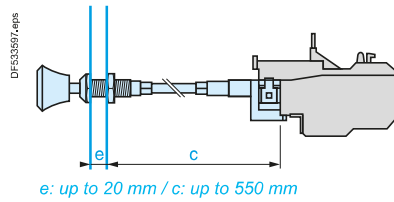

Mounting with cable bent

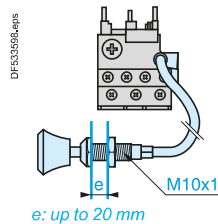

Overload
relays

TeSys Protect

Deca Electronic overload relays

Schemes

LR9D01, 02, 08, 32

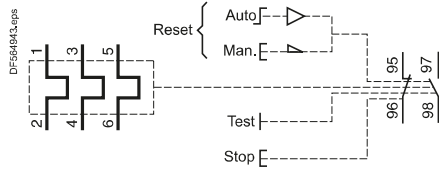

LR9D01, 02, 08, 32, LR9 D110S

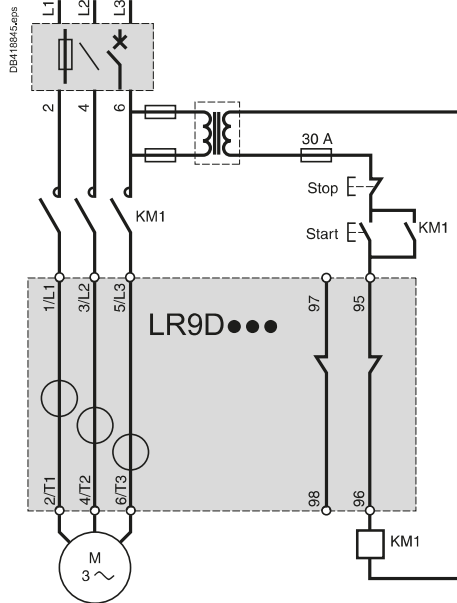

LR9D5●●●

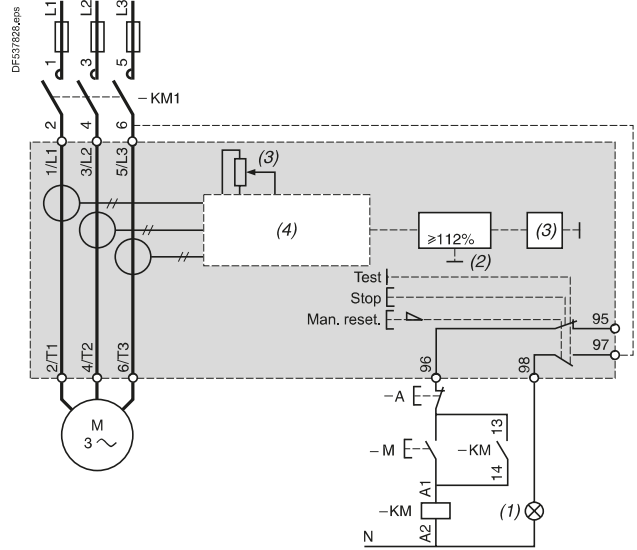

- (1) Tripped.
- (2) Overload.
- (3) Setting current.
- (4) Specialised circuit.

LR9D67 and LR9D69

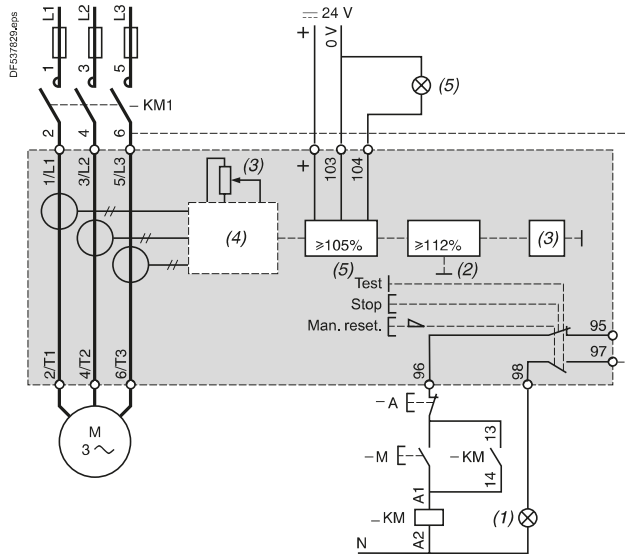

- (1) Tripped.
- (2) Overload.
- (3) Setting current.
- (4) Specialised circuit.
- (5) Alarm.

References:
page B11/10

Characteristics:
pages B11/38 to B11/41

Dimensions:
page B11/42



TeSys Protect

Giga Electronic overload relays

Characteristics

Environment					
Contactor type		LR9G115	LR9G225	LR9G500	LR9G630
Conforming to standards		IEC/EN 60947-4-1, IEC/EN 60947-5-1, UL 60947-4-1, CSA C22.2 n° 60947-4-1, UL 60947-5-1, CSA C22.2 n° 60947-5-1, GB/T 14048.4			
Product certifications		CB Scheme, CCC, cULus, UKCA, ATEX, EU-RO-MR by DNV			
Degree of protection	Conforming to IEC 60529 / VDE 0106	IP 20 on front of relay with accessories LA9G37●●			
Climatic withstand		according to IACS E10			
Ambient air temperature around the device (conforming to IEC 60255-8)	Storage	°C	-55...+80		
	Normal operation	°C	-25...+60		
Maximum operating altitude	Without derating	m	3000		
Net weight		kg	1.2	1.7	2.8
Operating positions without derating	In relation to normal vertical mounting plane	Any position			
Shock resistance 11 ms	Permissible acceleration conforming to IEC 60068-2-7	15 gn			
Vibration resistance 5 to 300 Hz	Permissible acceleration conforming to IEC 60068-2-6	6 gn			
Rated impulse withstand voltage (Uimp)	Conforming to IEC 60947-4-1	kV	8		
Surge withstand	Conforming to IEC 61000-4-5	kV	4		
Resistance to electrostatic discharge	Conforming to IEC 61000-4-2	kV	8 (in air) 6 (in direct mode)		
Resistance to radiated radio-frequency disturbance	Conforming to IEC 61000-4-3	V/m	20		
Resistance to fast transient currents	Conforming to IEC 61000-4-4	kV	4		
Electromagnetic compatibility	EN 50081-1 and 2, EN 50082-2	Conforming			



Ref.







TeSys Protect

Giga Electronic overload relays

Characteristics

Power circuit - Electrical characteristics				LR9G115	LR9G225	LR9G500	LR9G630
Relay type							
Rated insulation voltage (Ui)	Conforming to IEC 60947-4-1 Over-voltage category III, degree of pollution: 3	V	1000				
Rated impulse withstand voltage (Uimp)	Conforming to IEC 60947-1	kV	8				
Rated operational current (Ie)		A	28 to 630				
Short-circuit protection and coordination			See pages A5/7 to A5/8, A5/23 to A5/26 and A5/38 to A5/39.				
Frequency limits of the operating current		Hz	50 / 60				
Power circuit connections	Width of terminal lug	mm	18	18	30	48	
	Clamping screw		M8	M8	M10	M12	
	Tightening torque	N.m	18	18	35	58	

Auxiliary contact electrical characteristics										
Conventional thermal current		A	5							
Short-circuit protection	By gG fuses	A	6							
Connection (Push-in type)	Flexible cable	1 conductor with cable end	mm ² 	Min.	Max.					
				0.25	2.5					
	Solid cable	2 conductors with Dual Sleeve	mm ² 	0.5	1					
				1 conductor	mm ² 	0.2	2.5			
	Stripping length	mm 	10			10				
Rated operational contact power	a.c. supply AC-15	V	24	48	120	240	380	480	500	
		A	4	4	3	1.5	0.95	0.75	0.72	
		VA	96	192	360	360	361	360	360	
	d.c. supply DC-13	V	24	48	125	250	–	–	–	
		A	2	0.7	0.22	0.11	–	–	–	
		W	48	33.6	27.5	27.5	–	–	–	
Maximum operational voltage	a.c., category AC-15	V	500	500	500	500	500	500	500	
	d.c., category DC-13	V	250	250	250	250	250	250	250	



Overload relays

TeSys Protect

Giga Electronic overload relays

Characteristics

Operating characteristics

Tripping class	Conforming to IEC 60947-4-1		5E/10E/20E/30E
Operating temperature		°C	-40...+60 ⁽¹⁾
Reset			auto and manual
Trip alarm and fault indication			On front of relay
Test function			On front of relay
Tripping thresholds	Conforming to IEC 60947-4-1	Alarm Tripping	≥ 90% of permissible thermal state 1.2 ± 0.05 I _r
Sensitivity to phase loss	Conforming to IEC 60947-4-1		Tripping in 4 s ± 1 s in the event of phase loss
Phase imbalance	Conforming to IEC 60947-1		Tripping in 5 s ± 1 s if imbalance ratio ≥ 40 % according to Annex T5.5
Ground fault	Conforming to IEC 60947-4-1		I _g = 0.75 I _r Tripping 1 s ± 20 % if I ≥ 1.1 I _g
Adjustment (nominal motor current)			Setting dial on front of relay (64 settings)
Security sealing			Yes

(1) Adjustment of dial setting(s): -25...+60 °C.

LR9G tripping curves

Average operating times depending on multiples of the setting current

Class 5E

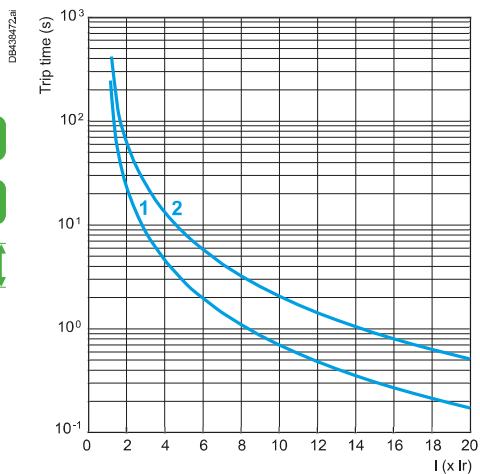

- 1 Hot state
- 2 Cold state

Class 10E

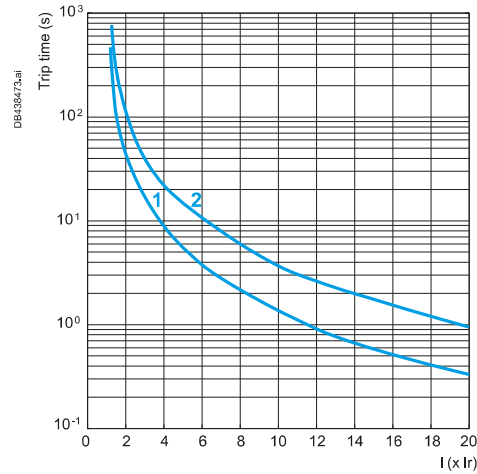

- 1 Hot state
- 2 Cold state

Class 20E

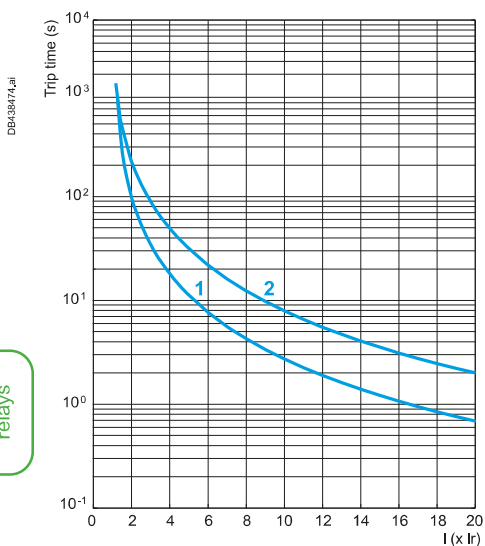

- 1 Hot state
- 2 Cold state

Class 30E

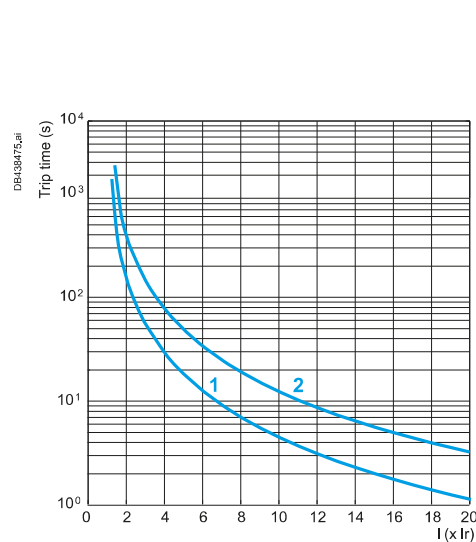

- 1 Hot state
- 2 Cold state

Introduction:
pages B11/11 to B11/12

References:
pages B11/13 to B11/14

Dimensions:
page B11/47



TeSys Protect

Giga Electronic overload relays

Dimensions and diagram

Dimensions

LR9G115...630

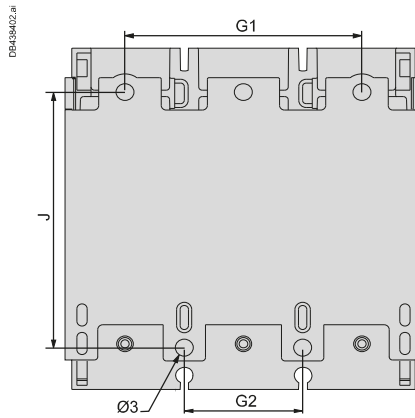
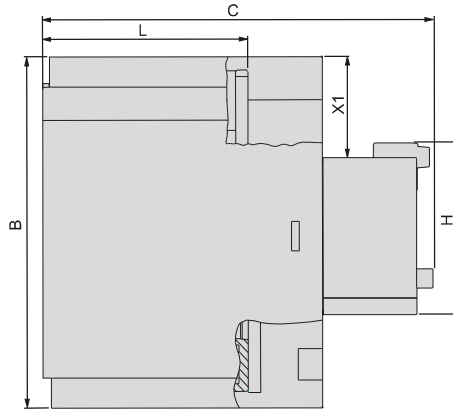
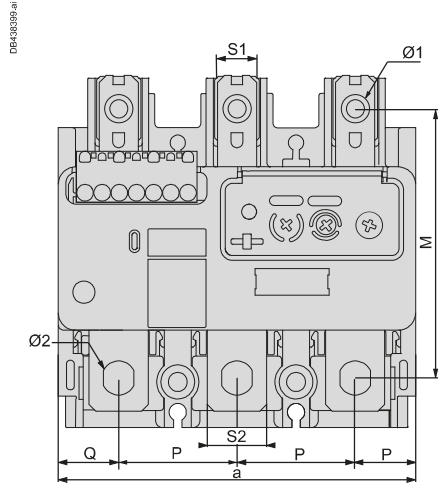

LR9G	115-225	500	630
a	105.7	140	210
b	109.55	115.65	149.45
c	126.2	139.2	185.9
G1	70	119.3	186.2
G2	35	45	70
J	80.1	68.25	86
M	78	83	100
H	52	52	52
L	66	79	107
P	35	45	70
Q	18	25	35
S1	11.5	22.5	22.5
S2	17.5	30.5	50
Ø1	8.3	10.6	13
Ø2	9	10.6	13
Ø3	5.3	5.3	8.5
X1	30	33	50

Diagram

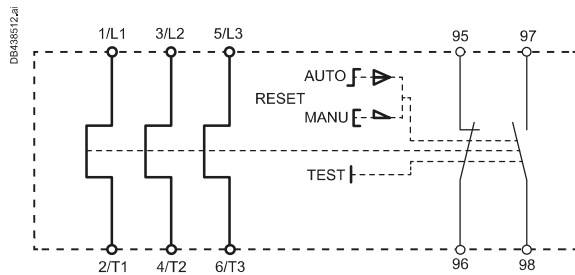

Overload relays

TeSys Protect

RM1XA Magnetic overload relays

Characteristics

Introduction

The RM1XA electromagnetic relay detects over current peaks in excess of the maximum permissible current value. It is designed for the protection of circuits which are not subject to current peaks (starters, resistors) or for controlling starting peaks on slip ring motors.

It trips instantaneously and is not suitable for frequent operation (12 operating cycles per hour). It can withstand a continuous current equivalent to 1.25 times the minimum setting current.

Environment characteristics

Conforming to standards		IEC/EN 60947-4-1
Product certifications		UKCA
Ambient air temperature around the device	°C	Storage: - 60...+ 70 Operation: - 40...+ 60
Maximum operating altitude	m	2000
Operating position		± 15° in relation to normal vertical mounting position

Electrical characteristics of power circuit

Maximum rated operational voltage	V	~ or --- 600
Frequency limits of the rated operational current	Hz	0...60

Electrical characteristics of auxiliary contacts

Conventional thermal current	A	10						
Occasional making and breaking capacities	a.c. supply	Voltage	V	48	110	220	380	600
		Power ⁽¹⁾	VA	4000	12 000	17 000	22 000	—
	d.c. supply	Voltage	V	48	110	220	440	600
		Power ⁽²⁾	W	240	200	190	180	180

(1) Circuit such as the electromagnet of a contactor - $\cos \phi$ inrush: 0.7 and $\cos \phi$ sealed: 0.4.
 (2) Circuit such as an electromagnet without economy resistor ; time constant varying from 20 ms for 5 W to 200 ms for 100 W or more.

Operating times

Operating times: because of the numerous applications for RM1 XA over current relays, it is not possible to give precise operating times. The curves shown are therefore purely indicative.

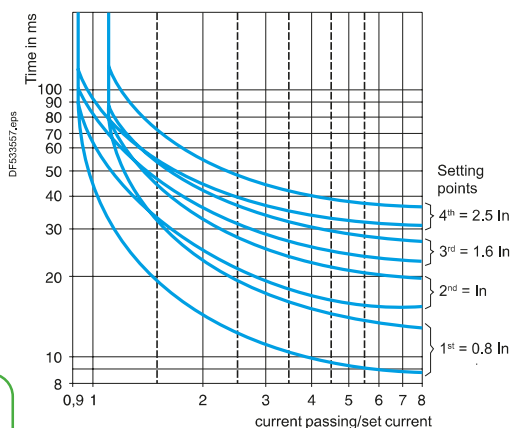

Overload relays

TeSys Protect

RM1XA Magnetic overload relays

Dimensions, schemes

Dimensions

RM1XA●●●,
RM1XA●●●1

RM1XA001...XA040

RM1XA100, RM1XA315
and RM1XA351

RM1XA160, RM1XA500

Common side view

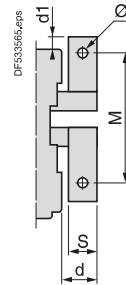
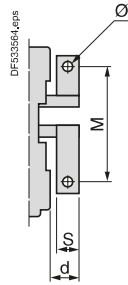
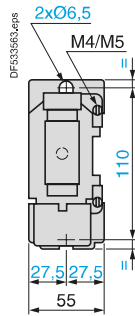
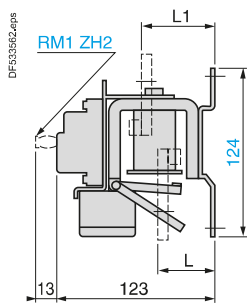

RM1XA●●●1 with electrical reset ER1XA2●

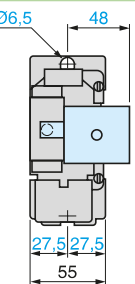
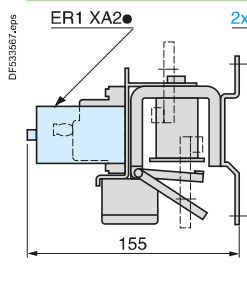

RM1	d	d1	M	L	L1	S	Ø
XA100	20.5	—	87	25	40	20	M8
XA160	27.5	5.5	94	25	40	25	M8
XA315	35.5	—	74	44	55	30	M10
XA500	40.5	7	84	44	55	40	M10

Schemes

RM1XA●●●1

Latching

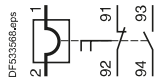

RM1XA●●●

Non-latching

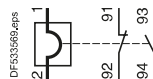

RM1XA

3-wire control (without
mechanical latching)

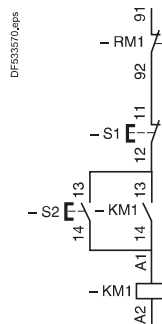

2-wire control (with
mechanical latching)

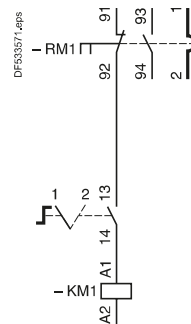

3-wire control
(with "trip" signal)

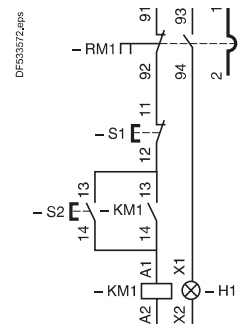

Ref.



Ref.



Application

LT3S● thermistor protection units continuously monitor the temperature of the machines to be protected (motors, generators, etc.) by means of PTC thermistor probes embedded in the machine windings.

If the nominal operating temperature of the probes is reached, they convert the rapid increase in resistance into a switching function which can be used to switch off the machine or signal a fault (see paragraph relating to thermistor probes below).

Accidental breaks in the supply circuits of the thermistors are also detected.

Electromagnetic compatibility

Conforming to "Electromagnetic compatibility" directive.
 Conforming to standard IEC/EN 61000-6-2.

Resistance to electrostatic discharge (conforming to IEC 61000-4-2)	Level 3
Resistance to fast transients (conforming to IEC 61000-4-4)	Level 3
Susceptibility to electromagnetic fields (conforming to IEC 61000-4-3)	Level 3
Surge resistance 1.2/50 - 8/20 (conforming to IEC 61000-4.5)	Level 4
Immunity to microbreaks and voltage drops (IEC 61000-4-11)	

Suitable for use with variable speed controllers

Thermistor probes

Range of most commonly used PTC thermistor probes:
 from 90 to 160 °C, in steps of 10 °C.

Curve $R = f(\theta)$, characteristic of a PTC thermistor probe, is defined by standard IEC 60947-8.

The choice of PTC thermistor probe to be incorporated in the motor winding depends on the insulation class, the type of motor and the most suitable location for the probe. This choice is usually made by the motor manufacturer or the motor rewinder, who have all the necessary information.

Application example

Insulation class of rotating machines conforming to IEC 60034-11 (S1 duty)	NOT Nominal operating temperature	Temperature at which rapid increase in resistance occurs	
	°C	Probes used for Alarm °C	Fault °C
A	100	100	100
B	110	110	120
E	120	120	130
F	140	140	150
H	160	160	170

(1) PTC: Positive Temperature Coefficient.

Overload relays

TeSys Protect

LT3 Thermal protection units

Characteristics

Protection unit type		LT3SE	LT3SA	LT3SM			
Reset method		Automatic	Automatic	Manual/Automatic			
Fault indication		–	On front panel of unit and remote	On front panel of unit and remote			
Fault test		–	–	By pushbutton on front panel of unit			
Probe interchangeability		Label "Mark A" to IEC 60034-11	Label "Mark A" to IEC 60034-11	Label "Mark A" to IEC 60034-11			
Environment							
Conforming to standards		IEC 60947-8	IEC 60947-8	IEC 60947-8			
Product certifications		UL, CSA					
Degree of protection		IP 20 conforming to IEC 60529					
CE marking		LT3S● protection units have been designed to comply with the basic recommendations of European directives relating to low voltage and EMC. Therefore LT3S● products bear the European Community CE mark.					
Ambient air temperature around the device	Storage Conforming to IEC 60068-2-1 and 2-2	°C	- 40...+ 85				
	Operation	°C	- 25...+ 60				
Maximum operating altitude	Without derating	2000 m					
	With derating	Up to 3000 m, the maximum permissible ambient air temperature for operation (60 °C) must be reduced by 5 °C per additional 500 m above 1500 m					
Vibration resistance	Conforming to IEC 60068-2-6	2.5 gn (2...25 Hz) 1 gn (25...150 Hz)					
Shock resistance	Conforming to IEC 60068-2-27	5 gn (11 ms)					
Operating positions without derating	In relation to normal vertical mounting plane	Any position					
Power supply circuit characteristics							
Rated control circuit voltage (Uc)	~ 50/60 Hz	Single voltage	V	115 or 230	–	400	
		0.85...1.1 Uc	Dual voltage	V	–	115/230	115/230, 24/48
	~ 50/60 Hz	Multivoltage	V	–	24...230	–	24...230
		0.85...1.1 Uc	–	–	–	–	–
	0.8...1.25 Uc	Single voltage	V	24	–	–	–
		Dual voltage	V	–	24/48	–	24/48
0.85...1.1 Uc	Multivoltage	V	–	24...230	–	24...230	
Average consumption	Sealed	~	VA	< 2.5	< 2.5	< 2.5 except (400 V: 2.7)	
		---	W	< 1	< 1	< 1	

(1) PTC: Positive Temperature Coefficient.

Ref.



Overload relays

TeSys Protect

LT3 Thermal protection units

Characteristics

Control circuit characteristics

Protection unit type			LT3SE		LT3SA		LT3SM	
Resistance	Tripping	Ω	2700...3100		2700...3100		2700...3100	
	Reset	Ω	1500...1650		1500...1650		1500...1650	
Maximum number of probes fitted in series ⁽²⁾	Probes ≤ 250 Ω at 25°		6		6		6	
Voltage at terminals in the thermistor circuit	Normal operation (R = 1500 Ω)	V	< 2.5		< 2.5		< 2.5	
	Conforming to IEC 60034-11 (R = 4000 Ω)	V	< 7.5		< 7.5		< 7.5	
Thermistor probe short-circuit detection	Operating threshold	Ω	–		< 20		< 20	
Connection of probes to the LT3	Distance	m	300	400	500	1000 ⁽³⁾		
	Minimum c.s.a. of conductors	mm ²	0.75	1	1.5	2.5		

Electrical characteristics of the output relay contacts

Contact type	Single voltage or dual voltage		1 N/C		1 N/C + 1 N/O		1 N/C + 1 N/O	
	Multivoltage		–		2 C/O		2 C/O	
Rated insulation voltage		V	~ 500					
Maximum operational voltage		V	~ 250 (~ 400 V for LT3SM00V)					
Rated impulse withstand voltage	Uimp	kV	2.5					
Conventional thermal current		A	5					
Operational power	At 220 V	VA	100 for 0.5 million operating cycles					
Breaking capacity	In cat. AC-15	120 V	A	6				
		250 V	A	3				
	In DC-13	24 V	A	2				
Cabling (cage type connector) for flexible or solid cable	Without cable end	mm ²	2 x 1...1 x 2.5					
	With cable end	mm ²	1 x 0.75...2 x 2.5					
Tightening torque		N.m	0.8					

Thermistor probe characteristics

Probe type			DA1TT●●●		DA1TS●●●	
Conforming to standards			IEC 60034-11, Mark A			
Resistance	At 25 °C	Ω	3 x 250 in series		250	
Rated operational voltage (Ue)	Per probe	V	--- 2.5 V max		--- 2.5 V max	
Rated insulation voltage (Ui)		kV	2.5		1	
Insulation			Reinforced		Reinforced	
Length of connecting cables	Between probes	mm	250		–	
	Between probe and motor terminal plate	m	1		1	

(1) PTC: Positive Temperature Coefficient.

(2) Provided that the total resistance of the probe circuit is less than 1500 Ω at 20 °C.

(3) For distances greater than 500 m take cabling precautions (twisted shielded pairs).

Ref.



Overload relays

LT3S protection unit/thermistor probe combination

Guaranteed operating zones: examples with 3 probes type DA1TT●●● (250 Ω at 25 °C) in series, conforming to standard IEC 60034-11, Mark A.

LT3SE, LT3SA, LT3SM protection units

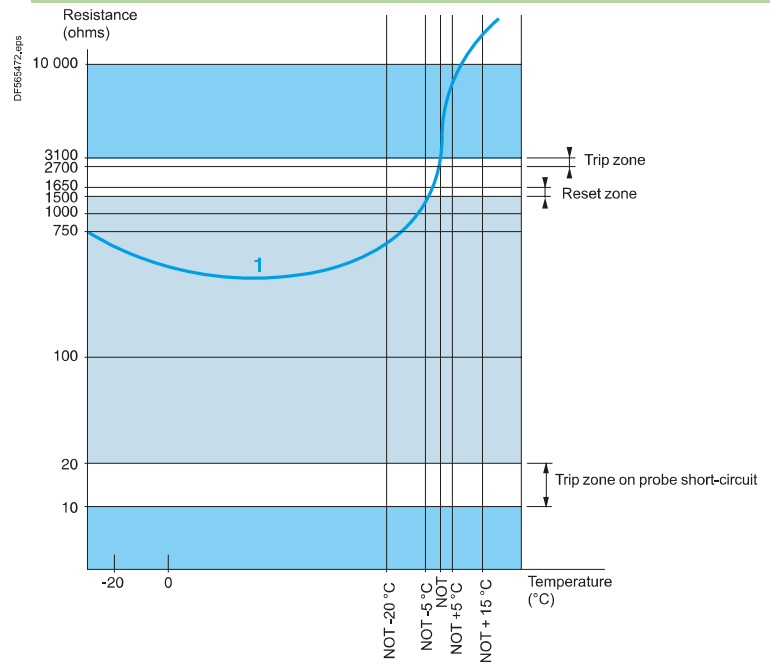

1 3 probes type DA1TT●●● (250 Ω at 25 °C) in series.

NOT: Nominal Operating Temperature

Protection unit tripped.

Protection unit reset.

(1) PTC: Positive Temperature Coefficient.

Ref.



Overload relays

TeSys Protect

LT3 Thermal protection units

Dimensions, schemes, setting-up

Dimensions

LT3SE, SA, SM

Mounting on 1 L rail AM1 DP200

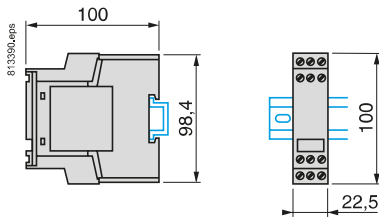

Mounting on 1 L rail (with adapter RHZ 66)

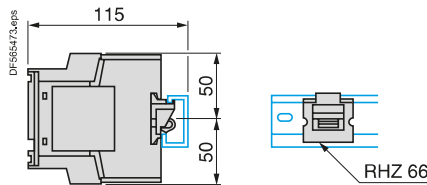

Schemes for "no fault" operation

LT3SE00BD (24 V DC), LT3SE00F (115 V AC), LT3SE00M (230 V AC)

Without fault memory

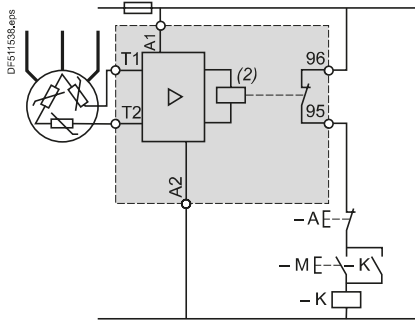

LT3SA00ED (24/48 V DC), LT3SA00M (115/230 V AC)

Refer to chart for use of A1/B1 terminal according power supply

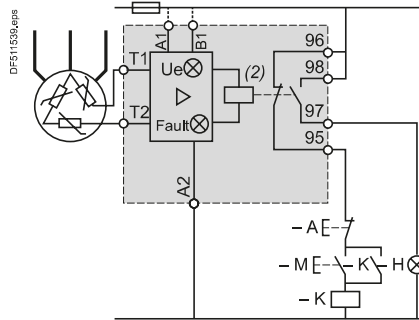

LT3SA00MW (24 to 230V AC/DC)

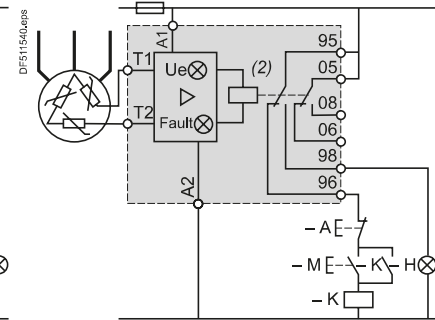

LT3SM00E (24/48V AC), LT3SM00ED (24/48V DC), LT3SM00M (115/230 V AC), LT3SM00V (400V AC)

Refer to chart for A1 - A2 - B1 supply terminals to be used

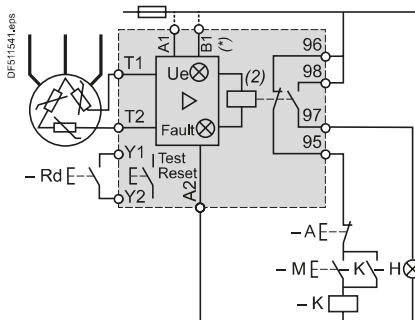

LT3SM00MW (24 to 230 V AC/DC)

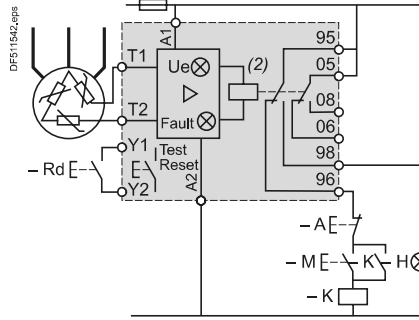

LT3SA, LT3SM - dual voltage and 400 V - power terminal assignment

	24 V DC	48 V DC
LT3SA00ED, LT3SM00ED	B1(+)	A1(+)
Terminals	A2 (0V)	A2 (0V)
LT3SA00M, LT3SM00M	115 V AC	230 V AC
Terminals	A1-B1	A1-A2
LT3SA00M, LT3SM00M	-	400 V AC
Terminals	-	A1-A2

(* no B1 terminal on LT3SM00V (400V AC).

Setting-up

Cabling

It is inadvisable to use the same multi-core cable for the thermistor probe circuit and the power circuit. This is especially important for long cable runs. If it is impossible to comply with the above recommendation, a pair of twisted conductors must be used for the thermistor probe circuit.

Testing the insulation of the line connecting the thermistors to the LT3S unit

Before carrying out this test, short-circuit all the terminals of the LT3S protection unit. Measure the insulation value between these terminals and earth using a megger or a flash tester, progressively increasing the voltage to the value defined by the standards.

Checking the PTC thermistor probes for correct operation

- With the machine stopped, in the cold state and after having taken all the necessary safety precautions:
- disconnect the line linking the thermistors to the LT3S protection unit, at the terminals of the machine being protected: motor, etc.,
 - using an ohmmeter with a voltage rating less than or equal to 2.5 V, measure the resistance of the probe circuit at the machine terminals,
 - depending on the number and type of thermistors connected in series, check that their resistance value at 25 °C is correct.

Example: motor fitted with 3 PTC thermistor probes with a resistance $\leq 250 \Omega$ at 25 °C. Any value higher than $250 \times 3 = 750 \Omega$ indicates a problem.

- (1) PTC: Positive Temperature Coefficient.
 (2) Relay energised: the contacts are shown in the "operating" position.

References: pages B11/17 and B11/18
 Characteristics: pages B11/50 to B11/53

Ref.



Overload relays

TeSys Protect

LT3 Thermal protection units

Schemes, operation

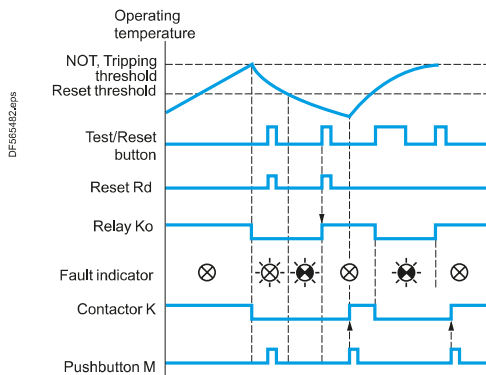
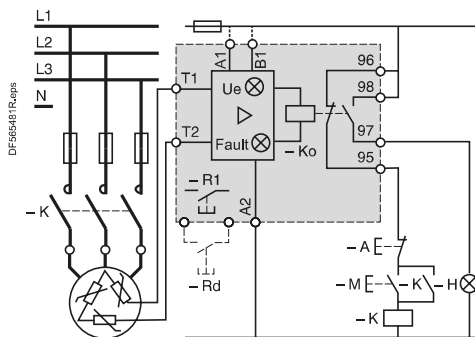
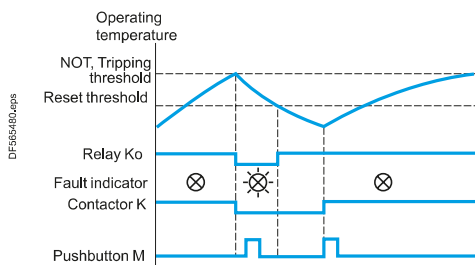
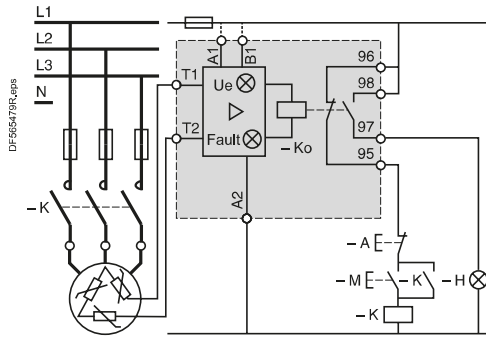

LT3SA protection units

Starting

The LT3SA is normally energised and its internal relay is in the pre-energised position.

The motor is started by operating pushbutton M automatically held in by K (3-wire control circuit).

Thermal fault

The strong increase in resistance of the PTC probes at the moment their temperature reaches the nominal operating temperature (NOT) is detected by the LT3SA unit and causes the relay to drop out; indicator H comes on, as does the built-in indicator on unit LT3SA.

Contactor K drops out and pressing button M has no effect.

Reset

As the motor cools, it reaches the reset threshold, 2 to 3 °C below the nominal operating temperature.

The relay resets and the motor can be started by pressing button M.

LT3SM protection units

Operation is very similar to that described above, except for the following:

Reset

After tripping on thermal fault and cooling to the reset threshold, the Test/RESET button on the unit (R1) or a remote reset button (Rd) must be pressed to energise the relay.

The fault is therefore memorised, even though the temperature of the probes has dropped to well below the reset threshold.

Signalling circuit

As the relay is fitted with 2 separate contacts, the signalling voltage may be different from the contactor control voltage.

Test

Pressing the Test/RESET button simulates a fault and causes the relay to drop out: the FAULT indicator comes on, as does the remote signalling indicator. The unit is reset by pressing the Test/RESET button again.

(1) PTC: Positive Temperature Coefficient.

TeSys Protect

LR97, LT47 Electronic over current relays

Characteristics

Introduction



LR97D



LT47

Ref.



LR97D and LT47 electronic over current relays have been developed to satisfy machine protection requirements. These relays have definite time characteristics: current threshold and time based function. They are particularly recommended for providing mechanical protection on machines with high resistive torque, high inertia and with strong probability of jamming under steady state conditions. They can be used for motor protection in the case of long starting times or frequent starting. The LR97D relay also incorporates two fixed time protection functions, one of 0.5 seconds against locked rotor and one of 3 seconds against phase failure. LR97D and LT47 can be used to provide mechanical shock protection. In this case, setting the O-Time knob to minimum will ensure tripping in 0.3 seconds. LR97D is designed to be directly connected downstream of the Deca contactor. LT47 provides two current transformers, to be crossed by the motor power cables.

Applications

LR97D and LT47 relays are particularly suitable for the following machines:

- Monitoring function for excessively long starting time on machines with a risk of difficult starting:
 - Machines with high resistive torque, high inertia machines.
 - Monitoring of machines during steady state operation: overtorque detection function
 - Machines with strong risk of jamming, machines with torque build-up over time,
 - Mechanical failure monitoring,
 - Faster detection of malfunctioning on machines where the motor is oversized in relation to its thermal protection I²t.
- Motor protection for specific applications:
 - Machines with long starting times,
 - Machines with high on-load factor: more than 30 to 50 starts/hour,
 - Machine with fluctuating load from a steady state, where the thermal image of a thermal overload relay (thermal memory) is unsuitable in relation to actual overheating of the motor.

Examples of machines:

- Conveyors, crushers and mixers,
- Fans, pumps and compressors,
- Centrifuges and spin-dryers,
- Presses, shearing machines, saws, broaching machines, sanders and lifting hoists.

Operation

Because of their two separate time settings, LR97D and LT47 relays can be combined with the motor-starter function:

D-Time: starting time, O-Time: trip time during steady state.

The D-Time function is only available during the motor starting phase. During this phase the overload detection function is inhibited in order to allow starting. Under steady state conditions, when the motor current is greater than the setting current due to an overload or single-phasing, the red LED lights up and the internal relay switches its contact after a time preset by the O-Time knob.

The red LED stays on, indicating that the relay has tripped.

The relays are simple to set, in 5 easy steps:

- Adjust the 3 knobs to maximum (Load, D-Time and O-Time),
- Adjust the D-Time knob to the value corresponding to the motor starting time.
- When the motor reaches steady state, adjust the Load knob (turn the knob counter-clockwise until the red LED starts to flicker).
- Slowly turn the Load knob clockwise until the LED goes out.
- Set the required tripping time, using the O-Time knob.

Description

Description

LR97D●●●●●

LT47●●●●●

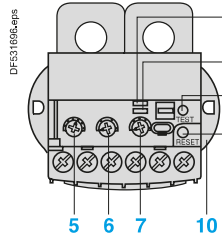
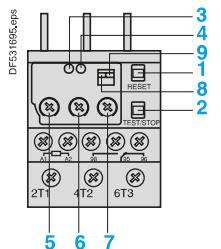

- 1 RESET knob
- 2 TEST/STOP knob
- 3 Ready/Run Indicator
- 4 Relay tripped indicator
- 5 Current setting
- 6 Adjustment of starting time
- 7 Adjustment of tripping time
- 8 Manual/Auto adjustment
- 9 Single-phase/3-phase adjustment
- 10 Retractable fixing lugs

Status signalling

LR97D●●●●●

LT47●●●●●

To assist fast diagnostics, two LEDs (one green and one red) allow signalling of the operating status:

Status	LED signal	
	Green LED	Red LED
Voltage	On	Off
Starting		
Steady state	On	Off
Overload	On	
Trip	Over-current	Off On
	Rotor locked	Off
Phase failure	L1	Off
	L2	Off
	L3	Off

Condition	LED signal	
	Green LED	Red LED
Voltage	On	Off
Starting		
Steady state	On	Off
Overload	On	
Trip	Off	On

TeSys Protect

LR97, LT47 Electronic over current relays

Characteristics

Curves

LR97D

Overload protection Protection against locked rotor and mechanical jamming under steady state conditions

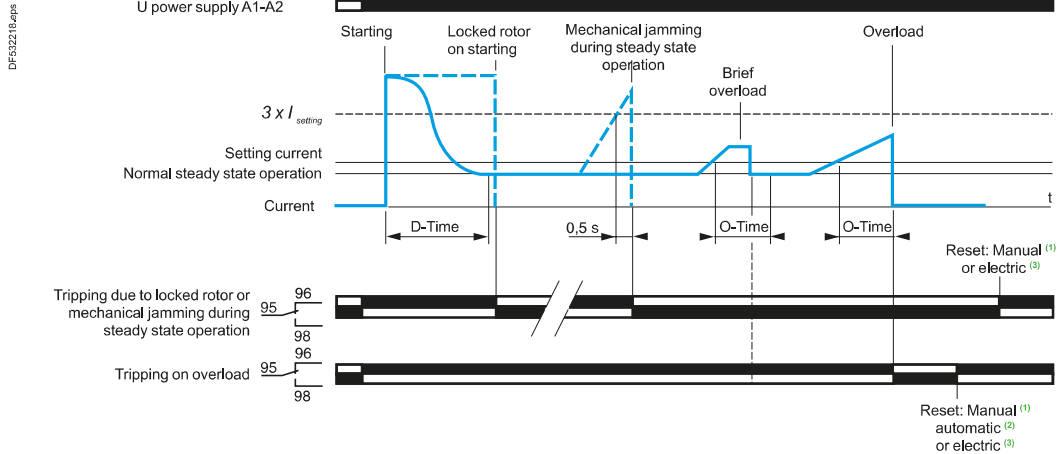

Overload protection Protection against phase failure during starting and during steady state operation

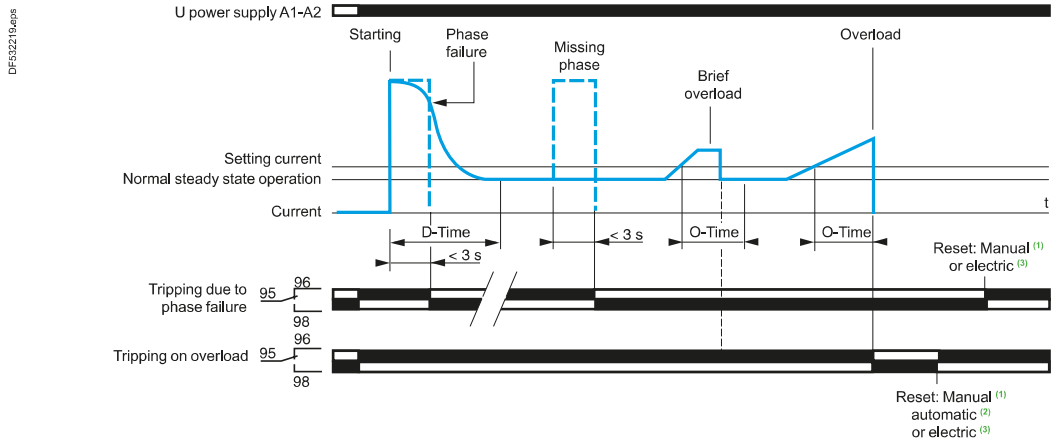

Mechanical shock protection

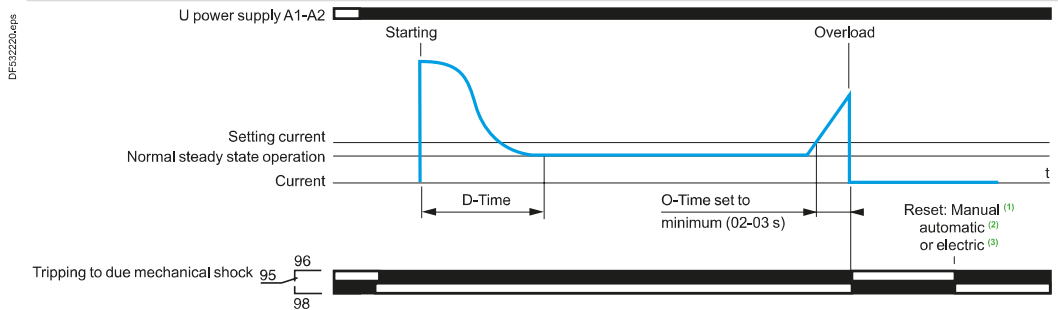

- (1) By Reset button.
- (2) Fixed time of 120 s. Selectable by dip switch. Function not available in the event of tripping due to locked rotor/mechanical jamming ($I > 3 \times I_{setting}$) or phase failure.
- (3) By brief interruption of power supply, minimum 0.1 s.

TeSys Protect

LR97, LT47 Electronic over current relays

Characteristics

Curves

LT47

Overload protection

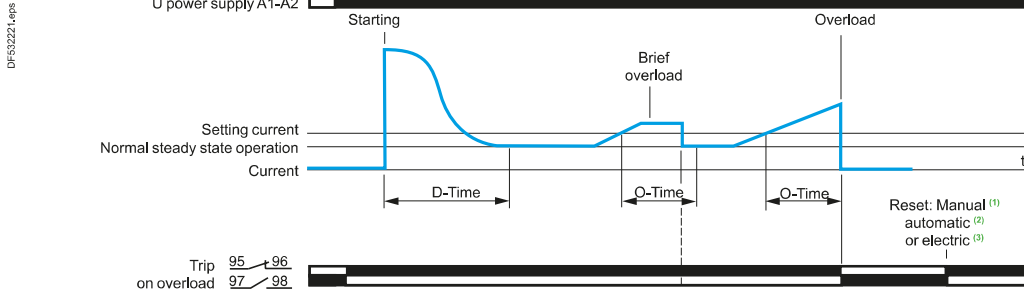

Mechanical shock protection

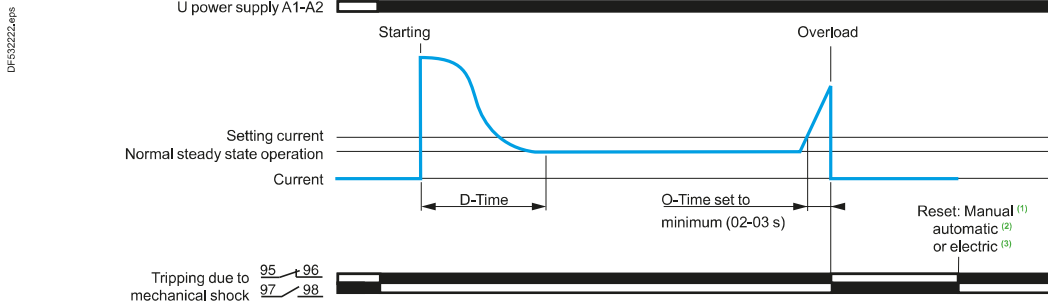

- (1) By Reset button.
 (2) Only available on version with automatic reset (LT47●●●●A). Time adjustable from 1 to 120 s with the R-Time knob.
 (3) By brief interruption of power supply, minimum 0.1 s.

Characteristics

Environment

Relay type		LR97D●●●●●	LT47●●●●●
Conforming to standards		IEC/EN 60947-4-1, IEC/EN 60947-5-1, UL 60947-4-1, CSA C22.2 n° 60947-4-1, UL 60947-5-1, CSA C22.2 n° 60947-5-1, GB/T 14048.5	IEC/EN 60947-4-1, IEC/EN 60947-5-1, UL 60947-4-1, CSA C22.2 n° 60947-4-1, UL 60947-5-1, CSA C22.2 n° 60947-5-1, GB/T 14048.5
Product certifications		UL, CSA, CCC, EAC	UL, CSA, CCC, EAC
Degree of protection	Conforming to IEC 60529	IP 20 (front face)	IP 20 (front face)
Ambient air temperature around the device	Storage	°C - 30...+ 80	- 30...+ 80
	Normal operation without derating (IEC 60947-4-1)	°C - 25...+ 60	- 25...+ 60
Maximum operating altitude	m	2000	2000
Operating positions without derating	In relation to normal vertical mounting plane	Any position	Any position
Shock resistance	Permissible acceleration conforming to IEC 60068-2-27	15 gn - 11 ms	15 gn - 11 ms
Vibration resistance	Permissible acceleration conforming to IEC 60068-2-6	4 gn	4 gn
Dielectric strength at 50 Hz	Conforming to IEC 60947-4-1	kV 2	2
Surge withstand	Conforming to IEC 61000-4-5	kV 6	6
Resistance to electrostatic discharge	In open air	kV 8 (level 3)	8 (level 3)
	In direct mode	kV 6 (level 3)	6 (level 3)
Immunity to radiated radio-frequency disturbance		V/m 10 (level 3)	10 (level 3)
Immunity to fast transient currents		kV 2	2
Conducted emissions	Conforming to EN 55011	Class A	Class A
Conducted HF disturbance	Conforming to EN 61000-4-6	V 10	10

TeSys Protect

LR97, LT47 Electronic over current relays

Characteristics

Characteristics										
Auxiliary contact characteristics										
Relay type			LR97D●●●●●				LT47●●●●●			
Contact type			1 NO/NC				1 N/O + 1N/C			
Conventional thermal current	A		3				3			
Maximum hold consumption of controlled contactor coils (occasional operating cycles of contact 95-96)	Conforming to IEC 60947	V	~ 24	~ 48	~ 110	~ 220	~ 24	~ 48	~ 110	~ 220
		VA	70	140	360	360	70	140	360	360
		V	~ 24	~ 48	~ 110	~ 220	~ 24	~ 48	~ 110	~ 220
		W	55	55	28	28	55	55	28	28
Short-circuit protection	By gG, BS fuses. Maximum rating or GB2 circuit breaker		A				3			
Connection by cable or lug-clamps										
Flexible cable without cable end	1 or 2 conductors	Min.	mm²	1 x 0.75			1 x 1			
		Max.	mm²	2 x 2.5			2 x 2.5			
Flexible cable with cable end	1 or 2 conductors	Min.	mm²	1 x 0.34			1 x 1			
		Max.	mm²	1 x 1.5 + 1 x 2.5			2 x 2.5			
External Ø of lugs			mm	7			7			
Ø of screw			mm	M3			M3.5			
Tightening torque			N.m	0.6...1.2			0.8...1.7			
Electrical characteristics of power circuit										
Relay type			LR97D015●● to LR97D25●●		LR97D38●●		LT47●●●●●			
Setting range	Depending on model		A		0.3...38		0.5...60			
Tripping class					Adjustable		Adjustable			
Rated insulation voltage (Ui)	Conforming to IEC 60947-4-1		V		690		690			
	Conforming to UL, CSA		V		600		600			
Rated impulse withstand voltage (Uimp)			kV		6		6			
Frequency limits	Of the operating current		Hz		50...60		50...60			
Connection by cable or lug-clamps										
Flexible cable without cable end	1 conductor	Min.	mm²	1.5	2.5	-				
		Max.	mm²	10	10	-				
Flexible cable with cable end	1 conductor	Min.	mm²	1	1	-				
		Max.	mm²	4	6	-				
External Ø of lugs			mm	10	12	-				
Ø of screw			mm	M4	M4	-				
Tightening torque			N.m	2	2	-				
Operating characteristics										
Relay type			LR97D●●●●●		LT47●●●●S		LT47●●●●A			
Adjustment	Current		A		"Load" knob		"Load" knob		"Load" knob	
	Time	D-time knob	s		0.5...30		0.5...30		-	
		O-time knob	s		0.2/0.3...10		0.2/0.3...10		0.2/0.3...30	
		R-time knob	s		-		-		1...120	
Reset	Manual				Reset button		Reset button		Reset button	
	Automatic				120 s fixed		-		R-time knob: 1-120 s	
	Electrical				By interruption of power supply (minimum 0.1 s)		By interruption of power supply (minimum 0.1 s)		By interruption of power supply (minimum 0.1 s)	
Protection functions										
Overload $I_{max} > I_{setting}$	Tripping			On starting	Steady state	On starting	Steady state	-		
				Inhibited during D-time	After O-time	Inhibited during D-time	After O-time	After O-time		
				After D-time	< 0.5 s	Inhibited during D-time	After O-time	After O-time		
Locked rotor, mechanical jamming $I > 3 \times I_{setting}$	Tripping			< 3 s	< 3 s	Inhibited during D-time	After O-time	After O-time		
Sensitivity to phase failure	Tripping			< 3 s	< 3 s	Inhibited during D-time	After O-time	After O-time		
Status and fault signalling (see table page 24517/2)					2 LEDs		2 LEDs		2 LEDs	
TEST/STOP function	Test				No load		No load		No load	
	Stop				Under load		Under load		Under load	
Sealing					Yes		Yes		Yes	

Ref.



Overload relays

TeSys Protect

LR97, LT47 Electronic over current relays

Dimensions, mounting, schemes

Dimensions

LR97D●●●●

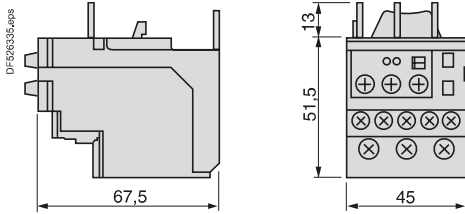

LT47●●●●

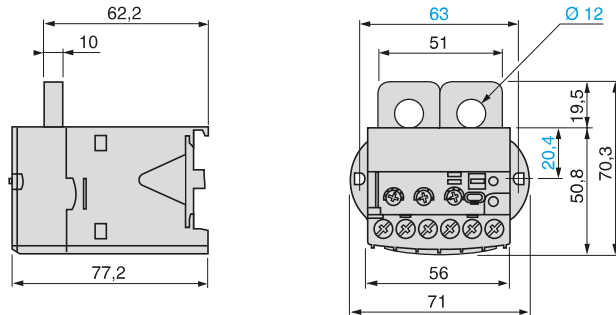

Mounting

LR97D●●●●

Direct mounting beneath the contactor

LT47●●●●

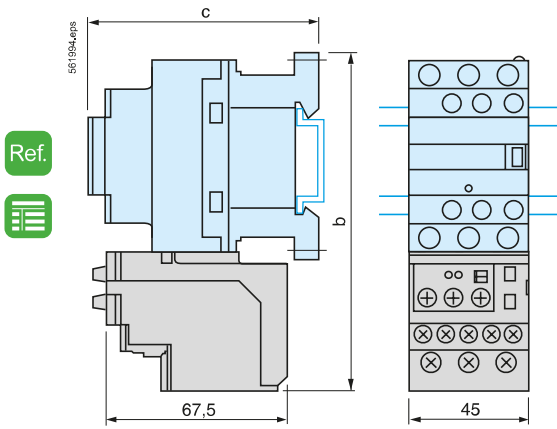

	LC1 D09...D18	D25...D38
b	123	137
c	See pages B8/76 and B8/77	

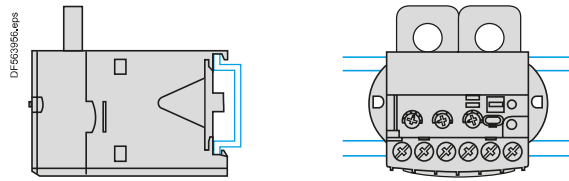

Note: Can be mounted on \perp rail.

Schemes

LR97D●●●●

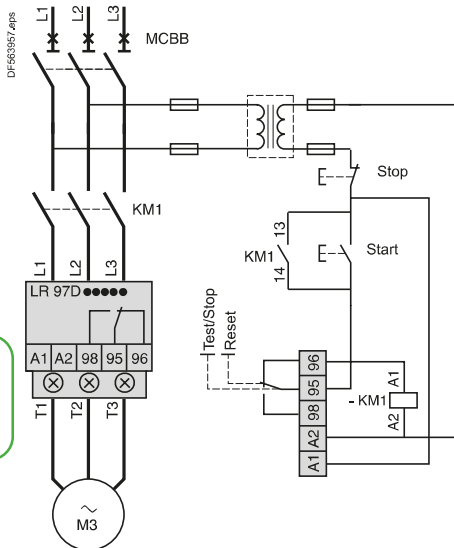

LT47●●●●

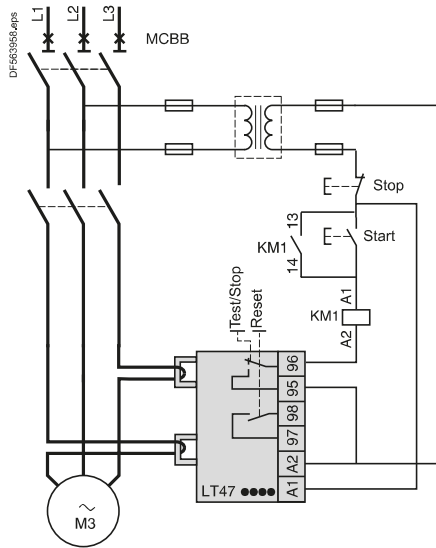

Overload relays